

Application Note  
**AN 16-001**

Revision:	00
Issue date:	2016-07-15
Prepared by:	Paul Drexhage
Approved by:	Joachim Lamp

Keyword: humidity, condensation, reliability, environment

# Effect of Humidity and Condensation on Power Electronics Systems

1. General .....	1
1.1 Condensation.....	2
1.2 Standards .....	3
2. Measurement .....	4
3. Effects on Power Electronics.....	4
3.1 Humidity .....	4
3.2 Condensation.....	6
4. Causes .....	7
4.1 Climate .....	7
4.2 Changes in relative air pressure .....	7
4.3 Changes in relative air temperature.....	7
4.3.1 Operating point.....	7
4.3.2 Temperature differentials ("cold spots") within a cabinet.....	8
4.4 Transport/storage .....	8
5. Mitigation Techniques .....	8
5.1 Cabinet heaters.....	9
5.2 Coolant temperature control in case of liquid cooled system .....	9
5.3 Fan control in case of air cooled system .....	10
5.4 Pre-heating procedures prior to start-up .....	10
5.5 Dehumidifiers .....	11
5.6 Vents.....	12
5.7 Desiccants.....	12
6. Examples .....	13
6.1 The ideal sealed cabinet.....	13
6.2 The ideal open cabinet.....	14
6.3 Interpreting the IEC climatogram .....	16

## 1. General

This application note describes the effect of humidity and condensation on power electronic systems. Design hints are provided to eliminate these effects for more reliable operation.

It is generally known that water in its most common form causes problems with electrical circuits due to its electrically conductive and corrosive nature. What is less commonly known is the effect that water has on electronics when in its gaseous state (water vapor). This vapor is diffused into the surrounding air and behaves according to the temperature and pressure of the atmosphere in a given volume. The presence of water vapor in air is referred to as humidity and is defined in different ways:

**Absolute humidity:** The mass of water vapor present in a volume of air, typically expressed as grams/cubic meter [g/m<sup>3</sup>]. Changes with volume.

**Relative humidity:** The ratio of the water vapor density (mass per unit volume) to the water vapor density at the saturation vapor pressure, typically expressed as a percentage [%]. Changes with air pressure and temperature as described in Figure 1.

**Air (dry) temperature:** The temperature of a mixture of air measured using a traditional thermometer, as opposed to the "wet bulb" temperature used in a hygrometer.

For most purposes, including this discussion, only *relative humidity* (RH) is used to define the moisture content in the air.

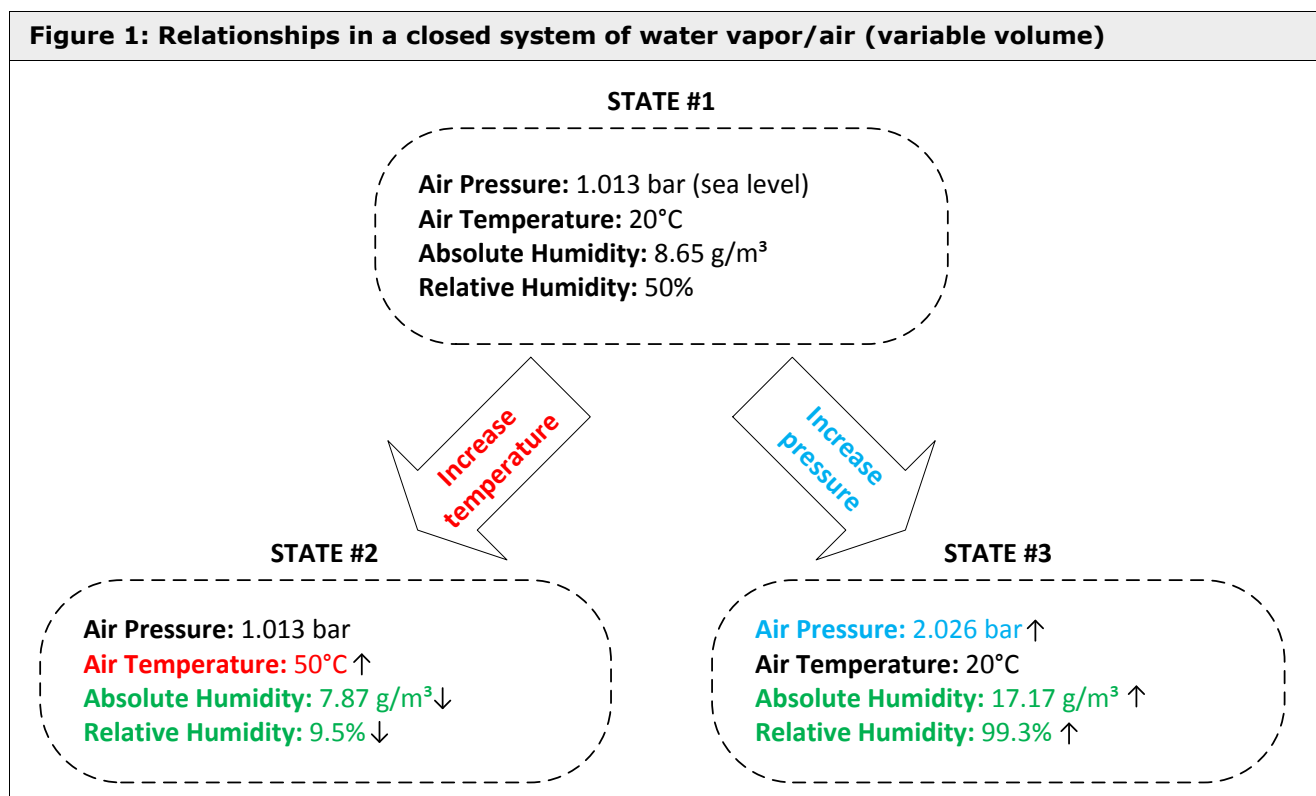

### 1.1 Condensation

When water vapor present in air changes state from a gas into a liquid, it forms condensation on surfaces (or frost in low temperatures). The temperature at which condensation occurs is called the dew point and varies with the relative humidity.

Figure 2 shows the relationship between relative humidity, air temperature, and dew point based on a Magnus equation approximation. For a given pressure and humidity, if the temperature of a volume of air (or object) drops below the dew point, condensation will occur in that area.

**Figure 2: Chart for determining dew point based on the Magnus equation (altitude = 0m)**

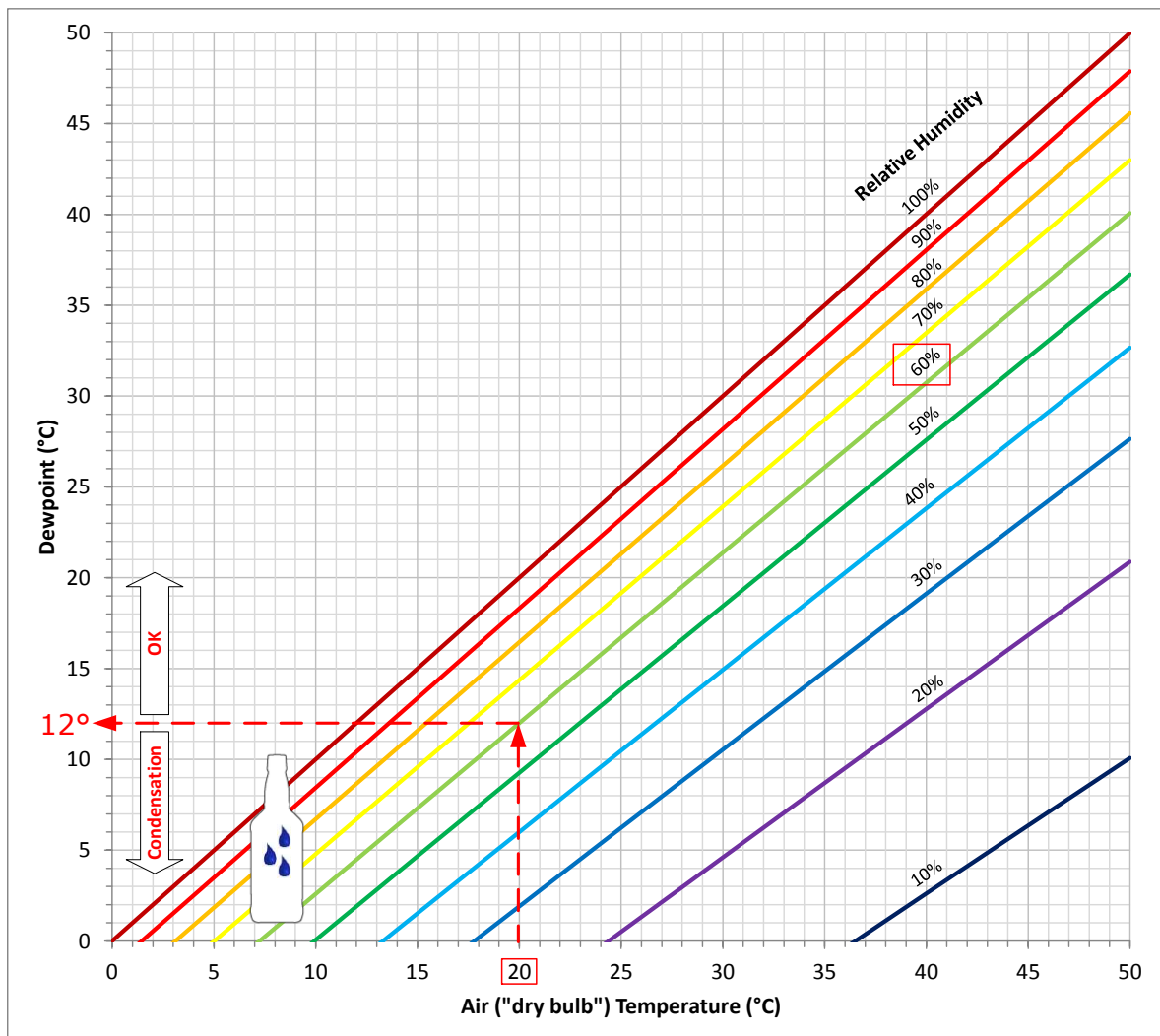

As a commonly used example, consider a room with a 20°C air temperature and a measured relative humidity of 60%. A chilled bottle of liquid (for example, 5°C) taken from a refrigerator and brought into the room will have water droplets condense on its sides. The chilled bottle has cooled the air in its immediate vicinity to below the dew point given on the chart (12°C). In fact, any parcel of air in this environment that is cooled below 12°C will cause the moisture it contains to condense into liquid.

## 1.2 Standards

The allowable humidity for most SEMIKRON products is given in IEC 60721-3-3 as climatic class 3K3. In addition to temperature and pressure ranges, this class gives an allowable range of relative humidity from 5% to 85%, without allowing for condensation to form. Furthermore, the absolute humidity is limited to 25g/m<sup>3</sup>. In order to maintain this environmental class it is critical that the temperature be regulated such that condensation is not allowed to occur.

The IEC standard uses a "climatogram" (differing from the English word used in meteorology) to define the allowable temperature and humidity limits. Similar to psychrometric charts, the IEC climatogram shows the relationship between air temperature, absolute humidity and relative humidity and can also be used to calculate the point at which condensation occurs (see Example in 6.3). The allowable climatic class is overlaid on the climatogram as a bold outline (Figure 3). While the 3K3 range only defines an allowable temperature range of 5° to 40°C, most SEMIKRON product have a larger allowable temperature range which results in an extended operating area as shown in blue in Figure 3. Therefore, in SEMIKRON datasheets the climatic class may be described as "3K3 modified" or "3K3 with extended temperature

range". Please consult the respective product datasheet or Technical Explanations for the product family for the exact climatic class.

**Figure 3: IEC 60721-3-3 climatogram for class 3K3 and "3K3 modified" for some SEMIKRON products**

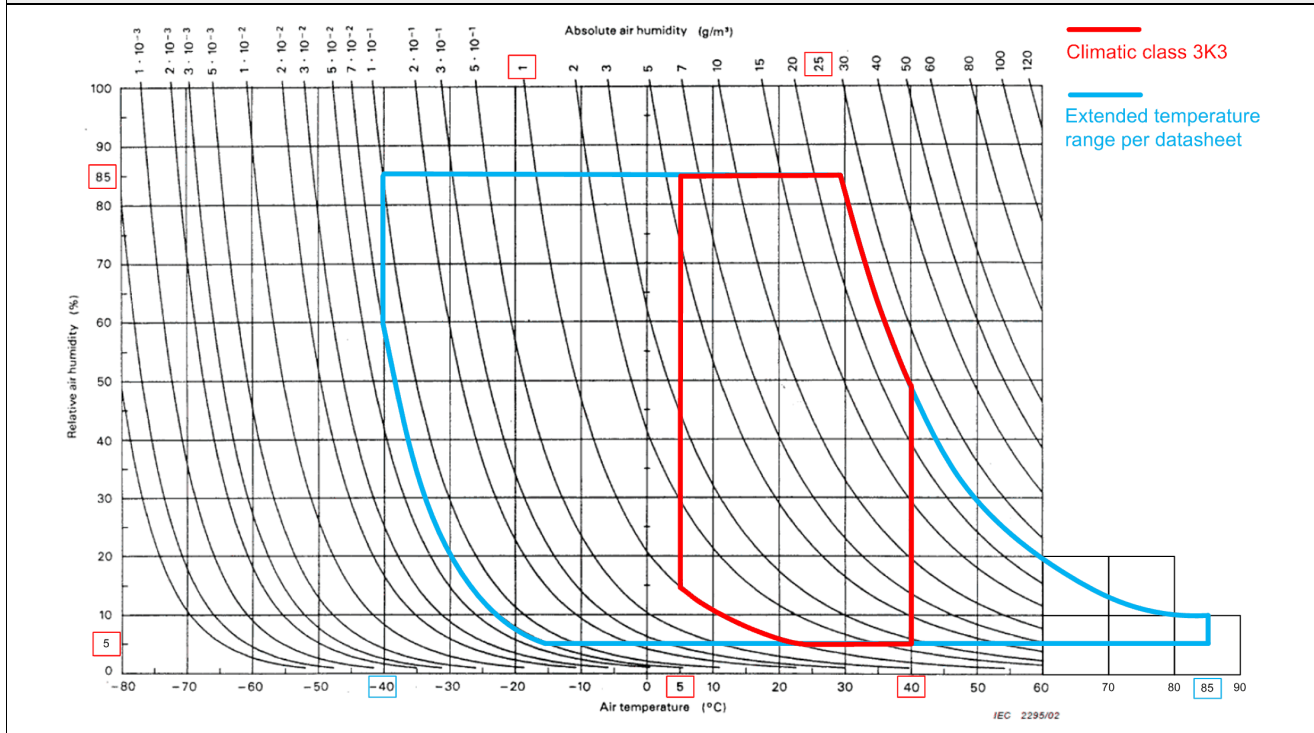

It is critical to understand that the climate class is constructed such that high relative humidity cannot occur at higher temperatures. While semiconductor chips are qualified in high humidity/high temperature environments, these environments are very stressful to these devices. Fortunately, for a closed environment with a fixed absolute humidity, it can be seen that the relative humidity falls with increased air temperature.

## 2. Measurement

Relative humidity can be measured directly using a hygrometer. Modern electronic industrial types consist of a capacitive or resistive sensor that can be calibrated to accuracy as high as  $\pm 2\%$  RH, but may be above  $\pm 10\%$  for uncalibrated or cheaper commercial types so caution must be exercised when interpreting results. Portable data logging types are typically coupled with a temperature sensor and advertised as "temperature/humidity data loggers" or "thermo-hygrometers".

As the internal humidity of an industrial cabinet is usually influenced by outside weather, it is recommended that both the interior and exterior relative humidity are measured over a period of days or weeks to understand how weather and working conditions play a role.

## 3. Effects on Power Electronics

### 3.1 Humidity

Most industrial power semiconductor modules consist of a plastic housing containing chips which have been encapsulated in a cured silicone-based gel ("soft mould", "sil-gel") that provides electrical insulation between conductors. However, the module is not hermetically sealed (gas tight) as atmospheric gas can permeate the module through openings at power terminals, etc.

The soft mould also contains diffused air (Figure 4). Therefore water molecules can also propagate through the soft mould in the same manner that they mix with air, albeit at a slower rate. Once inside the soft mould, the water molecules have the following effects:

1. Reduced blocking voltage: When the heat sink temperature decreases the diffused air inside the silicone holds less moisture. Water molecules will therefore accumulate on colder surfaces thermally coupled to the heatsink, such as the substrate, terminals and also semiconductor surfaces. Furthermore, the water molecules are attracted to the charged semiconductor surfaces due to their dipole characteristic and align themselves in the electric field (Figure 5). This leads to disruption of electric field lines at the semiconductor edge termination which can lead to reduced blocking voltage.
2. Semiconductor corrosion: The effect of corrosion on semiconductor chip passivation is well-known [7]. With applied voltage and humidity the chip edge passivation corrodes until breakdown occurs and the semiconductor fails. The semiconductor corrosion is a long term aging effect which is investigated in power module reliability testing. This testing is known as "High Humidity High Temperature Reverse Bias (H<sup>3</sup>TRB)" testing.

Unfortunately, the resulting failures from these effects are usually catastrophic and it can be very difficult to conclusively identify humidity as the root cause by examining only the destroyed module.

It is critical to note that the silicone gel responds quite differently to water in liquid form. Testing by silicone gel manufacturers has shown that the gel absorbs very little water liquid (<0.5%) when immersed.

**Figure 4: Water molecules diffuse into the silicone gel**

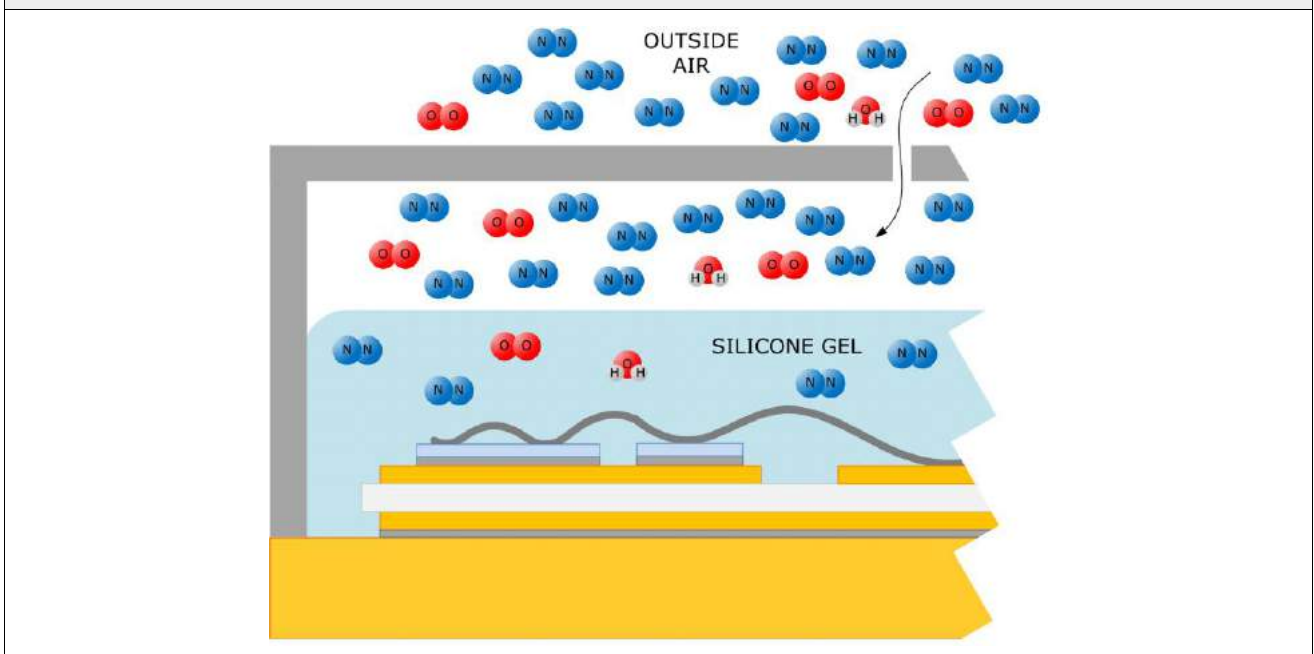

**Figure 5: Water molecules accumulate on surfaces, driven by their dipole characteristic and condensation**

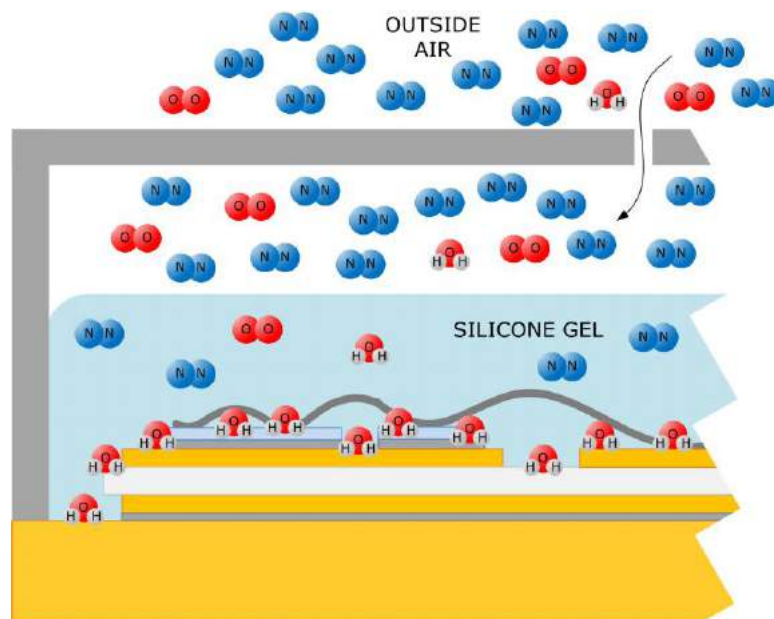

### 3.2 Condensation

Once water vapor has condensed into a liquid the effects on electronics are much more obvious. Droplets of water forming on a heatsink may wick into the housings of power modules (Figure 6).

**Figure 6: Evidence of liquid having been present on SKiiP heatsink near housing**

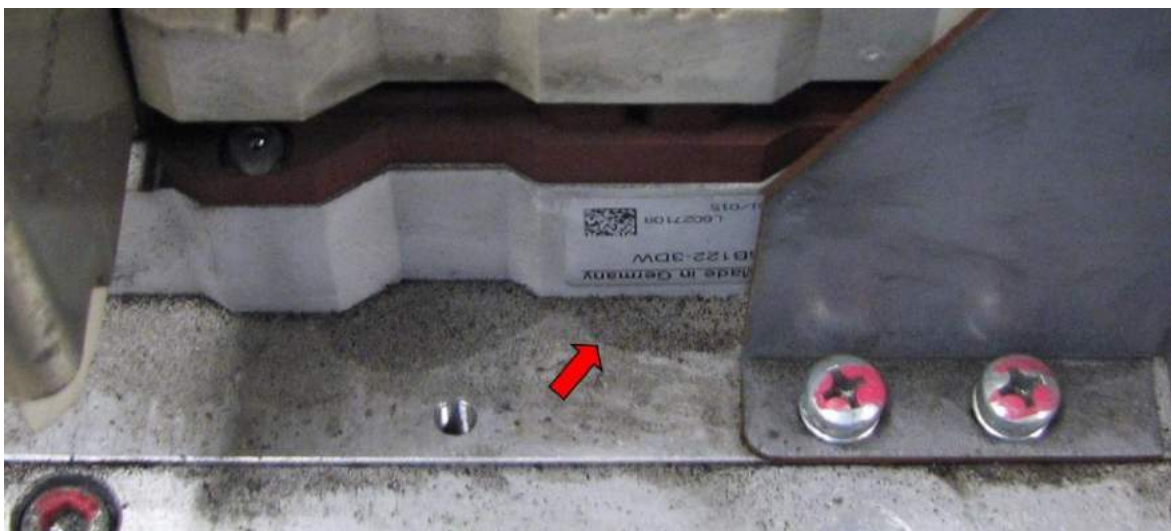

In the case of live conductors, such as in laminated DC link busplates, liquid can compromise the voltage withstand of the insulation material. Evidence of past condensation can possibly be seen in the form of water marks, particularly on dirty surfaces (Figure 7). However, it is oftentimes impossible to determine if condensation was present if the water has evaporated entirely.



**Figure 7: Evidence of liquid having been present on insulation of a DC link assembly**



#### 4. Causes

Humidity is a naturally occurring phenomenon and on a macro level will vary with location and weather. Within a micro-environment (e.g. electrical cabinet), the local relative humidity will be a function of the temperature and pressure, both of which can be influenced by the design of the electrical enclosure.

##### 4.1 Climate

It is generally understood that certain locations on earth are more prone to high humidity conditions than others (e.g. desert vs. tropics). However, even in relatively temperate climates, high humidity can occur depending on altitude, proximity to bodies of water, and seasonal effects. Most important is the micro-climate inside and immediately around the electrical cabinet.

##### 4.2 Changes in relative air pressure

Recalling Figure 1, it can be seen that an increase in pressure on a sealed system will drive up the relative humidity. In electrical cabinets that have been sealed to outside airflow, a (naturally occurring) change in air pressure (in the macro-environment) can result in high relative humidity within the cabinet. It is then a matter of:

1. Whether or not the water vapor inside the cabinet has been minimized or contained.
2. Whether elements within the cabinet drop in temperature below the dew point and cause condensation.

For sealed cabinets this air pressure differential may be reduced through the use of Vents, below.

##### 4.3 Changes in relative air temperature

###### 4.3.1 Operating point

One of the causes for temperature disparities within a unit is the operation of the system itself. Electrical operation of the system causes the temperature of components and the internal cabinet air temperature to rise. A sudden change in operation can cause the heatsink to cool much more rapidly than the air temperature of the enclosure (Figure 8), possibly creating a condition where the heatsink temperature falls below the dew point. Therefore it is critical to be aware of any changes from operation at full power to another mode, such as:

1. Light load.
2. Standby mode.
3. Unexpected interruption of operation (due to faults).

Note that this risk is also present when the air temperature drops during the transition between day and night. As the inlet air temperature (fed from outside ambient air) on an air-cooled heatsink drops in the evening the heatsink may be cooled to below the dew point.

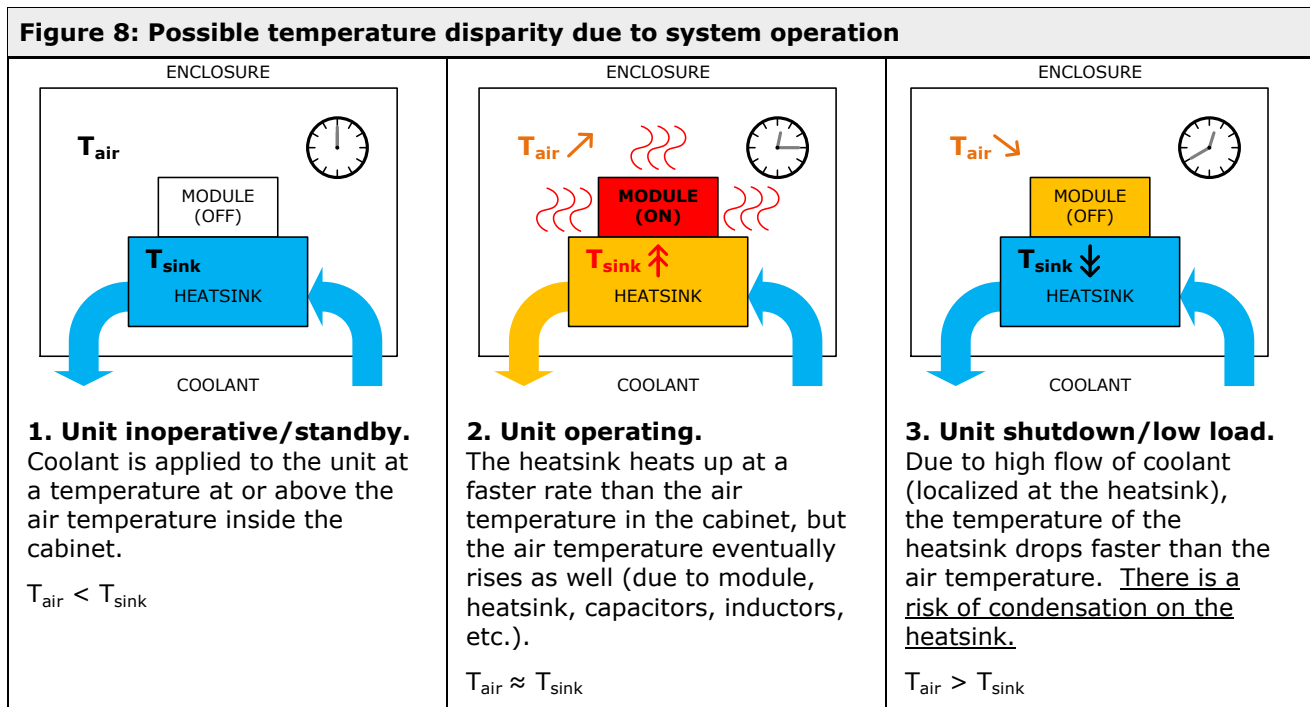

#### 4.3.2 Temperature differentials ("cold spots") within a cabinet

As a result of operation or simply due to cabinet design, condensation may occur on certain areas within the cabinet. Experience has shown the following areas have the highest risk:

1. Fresh air inlet ports.
2. Coolant inlet manifolds and piping.
3. Outer (metallic) walls of the cabinet.
4. Heatsinks and any components to which they are thermally coupled.
5. Areas with low air flow relative to other portions of the cabinet.
6. Large (dense) metallic components with a long thermal time constant.

Condensation on cabinet ceilings and walls may drop onto the power module, electronics or busbars, causing short circuits.

#### 4.4 Transport/storage

The previously stated causes of humidity may occur prior to the product being installed in the end location. Power electronics shipped over long distances or stored for long periods of time may acquire water vapor build-up within the packaging, potentially leading to catastrophic failure when voltage is applied. For this reason shipping packaging may include Vents or Desiccants, below. Furthermore, dry-out procedures can be employed to remove any water vapor present in a system prior to applying power.

### 5. Mitigation Techniques

The external macro-environment (and its associated pollution, temperature and humidity levels) is usually the main factor in determining whether an electrical cabinet is sealed or open.

For the purposes of this discussion a sealed (closed) cabinet is defined as one having an IEC ingress protection (IP) rating of 65 or higher. This means the cabinet is protected against dust ingress and low power water jets sprayed from any direction. However, this also implies that the airflow between the inside of the cabinet and the outside environment is limited and therefore differentials in temperature and



pressure might occur. Conversely, an open cabinet is defined as one in which there is a free exchange of the outside air with the inside of the cabinet. Temperature, humidity and pressure are allowed to equalize.

### 5.1 Cabinet heaters

As described previously, for a fixed absolute humidity, increasing the ambient (dry) air temperature will decrease the relative humidity. Industrial cabinet heaters are commercially available to facilitate this. Consisting of a resistive heating element, thermostat and occasionally a fan for air circulation these units serve to:

1. Dry the cabinet after initial commissioning.
2. Drive humidity out of a closed system when used with one-way permeable membranes.
3. Prevent condensation from forming on internal cabinet walls/ceiling.
4. Prevent condensation on internal metal parts when the external ambient gets hotter.
5. Pre-heat an electrical cabinet prior to operation (if the minimum operating temperature is not met) and protect the electronics during operation in low ambient temperatures.
6. Maintain active parts at higher-than ambient temperatures during stand-by.

While simple on/off operation is possible with a temperature set point (e.g. with a thermostat), a heater can also be controlled by a hygostat to ensure that the air temperature inside the cabinet does not fall below the dew point. Heaters should be placed at the bottom of the cabinet and should have sufficient power to heat the inner ambient to a defined level at a low external ambient temperature.

**Figure 9: Two 800W heaters installed in the base of a 2000mm x 800mm x 600mm cabinet**

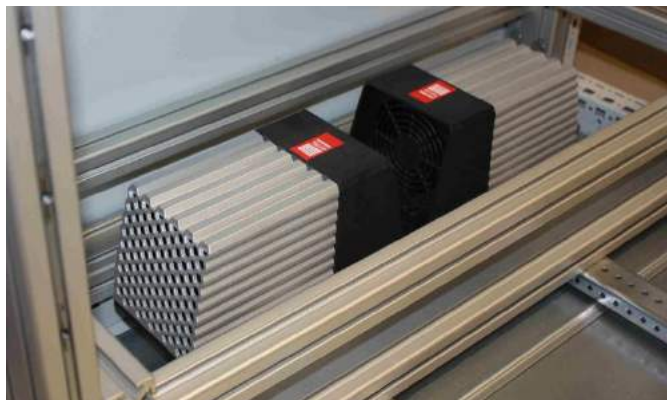

### 5.2 Coolant temperature control in case of liquid cooled system

The coolant temperature should be warm enough such that the heatsink surface temperature never drops below the dew point. Ideally the coolant temperature should be above the internal cabinet ambient temperature. Two methods for coolant temperature control are proposed (Figure 10):

1. Use of a three-way thermostatic control valve.

At low temperatures (a common set point is between 25°C and 30°C) the coolant will flow through a bypass loop and not through the heat exchanger. Upon reaching the set point the valve starts to open and tries to keep the temperature constant. At higher power the coolant flows entirely through the heat exchanger.

2. Use of a coolant heater.

Heating of the coolant is necessary to:

- a. Dry the cabinet after commissioning and when restarting after a long period of idle operation.
- b. Prevent condensation on the heat sink when the internal cabinet air temperature is hotter than the heat sink.

When using an efficient heat exchanger and/or operating at full power the inlet temperature is normally several degrees above the ambient temperature. At high internal cabinet temperatures with low load and high humidity it may be necessary to increase coolant temperature further to prevent condensation.

**Figure 10: Coolant loop with bypass and heater**

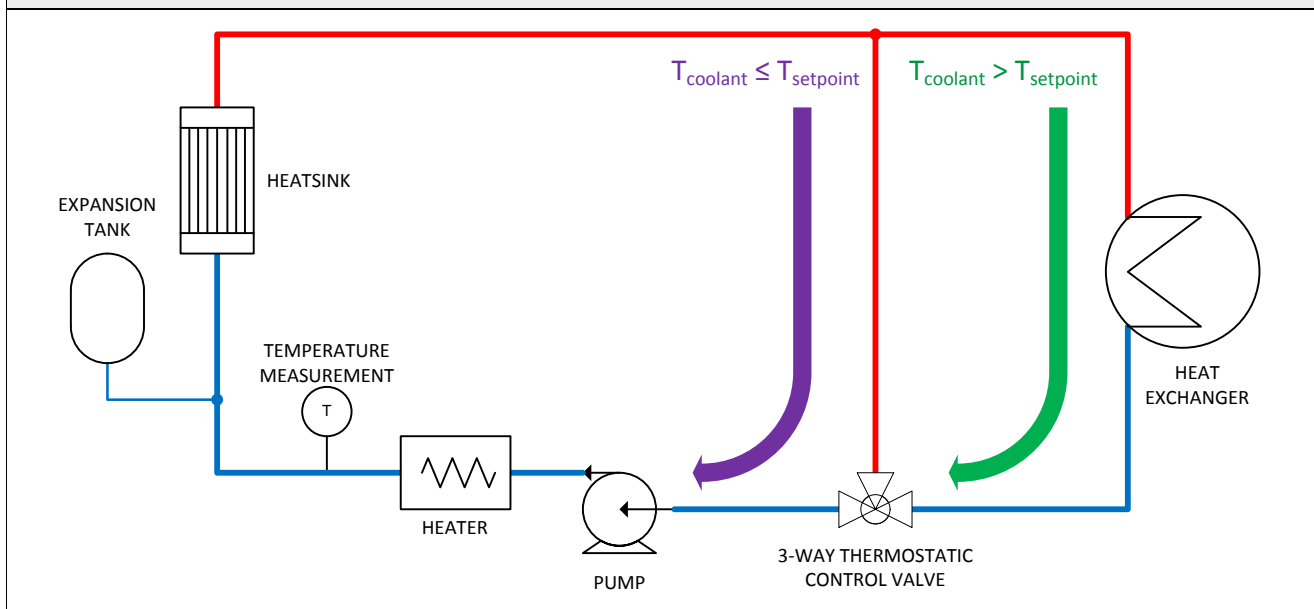

### 5.3 Fan control in case of air cooled system

In the case of forced air-cooled systems the heat sink temperature is regulated by varying the speed of the incoming air. The temperature of the heatsink is monitored and the fan speed is adjusted to prevent air below a minimum temperature from passing over the heatsink fins.

To implement this method the heatsink temperature close to the modules (or better yet, the sensor inside the power module) is monitored and a set point is selected. Below the set point the fan is completely off. After the set point is reached the fan starts to operate and increases speed as the temperature increases. At high loads the fan operates at full speed. This regulation method is costly but has the advantage that the stress on semiconductor and fan is low. In addition, overall system efficiency may be increased by reducing the power consumed by the fans when the converter load is low.

Some users implement simple on/off fan control ("bang-bang" or hysteretic) using a bi-metal switch on the heatsink. This has the disadvantage that the fan can be rapidly aged by the switching especially in the case of AC fans with motor start capacitors. More importantly the lack of a precise control loop causes rapid switching between "full on" and "full off" states resulting in large temperature differentials and additional aging in the semiconductor module. For example, an additional junction temperature swing of just 10°C reduces the module power cycling ability by a factor of 4 to 5. Therefore, this method of control is not recommended.

### 5.4 Pre-heating procedures prior to start-up

Experiments with power modules in an environment with 85% relative humidity have shown that using a coolant temperature at least 5°C hotter than the ambient air temperature will reduce the relative humidity inside the module.

Figure 11 describes the results of such a test in which the humidity beneath the silicone gel inside a module was measured as warm coolant (40°C) was applied in a high humidity environment with different ambient temperatures.

**Figure 11: Results of experiment involving heated coolant to reduce humidity**

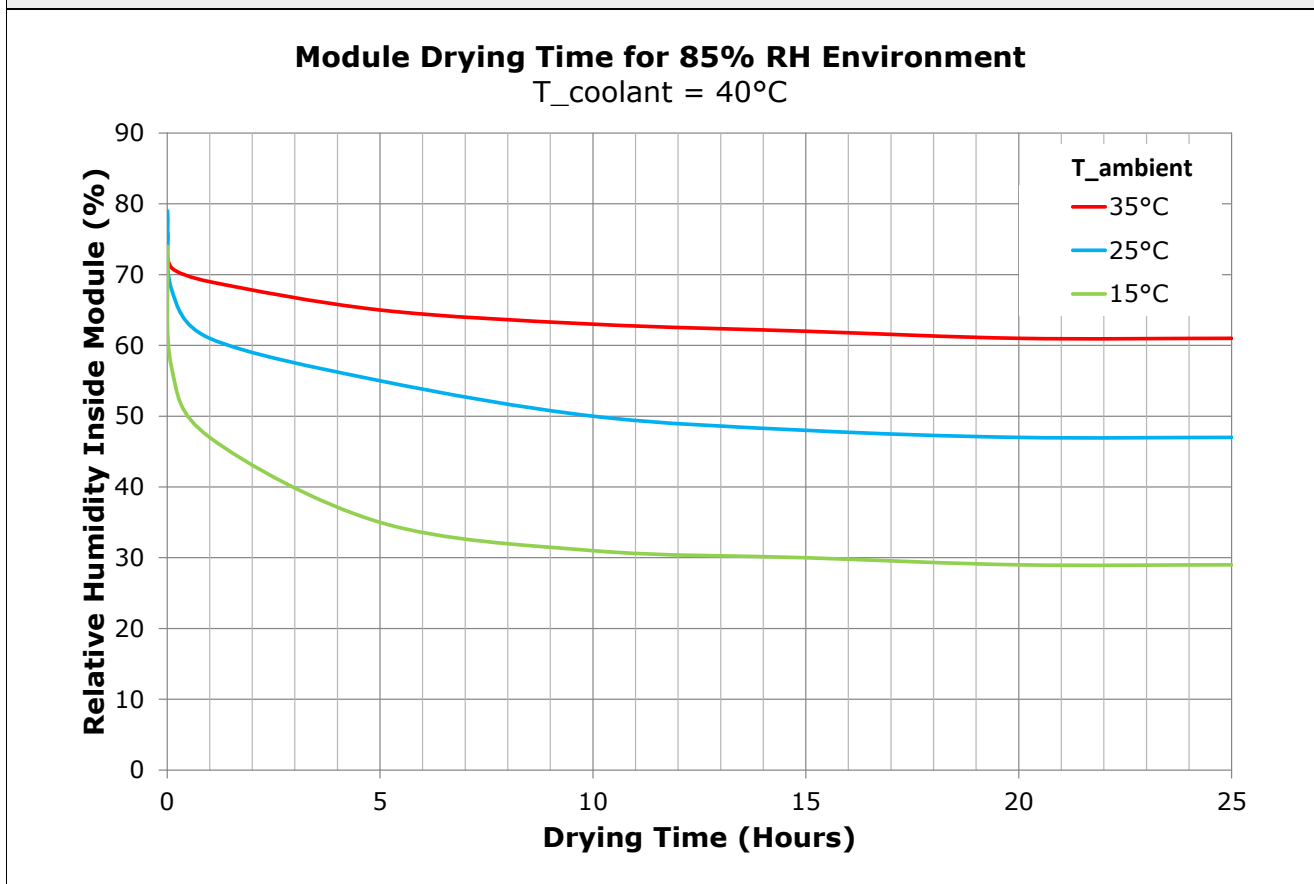

It can be seen that the steady state value of relative humidity is reached within 24 hours and that the characteristic roughly follows an inverse exponential curve. Based on the above test results and the known characteristics of the silicone gel, the following is recommended:

1. For systems where there is risk that the power electronics module has been exposed to high humidity during transportation or storage prior to initial operation (commissioning), coolant with a minimum temperature of 25°C and at least 5°C above the ambient air temperature should be applied for 24 hours prior to the application of high voltage (>50VDC).
2. For commissioned systems (installed outdoors or in high humidity environments) that have been inoperative for more than 8 hours, coolant with a temperature at least 5°C above the ambient air temperature should be applied for 1 hour prior to the application of high voltage (>50VDC).

## 5.5 Dehumidifiers

The most direct method of humidity reduction is to remove the moisture from the air using a dehumidifier. A dehumidifier consists of a cooled coil over which the humid air is forced. Moisture in the air condenses on the coil and is drained or pumped out of the system. Industrial cabinet dehumidifiers are available that differ from their commercial counterparts in the following ways:

1. Compact size to dry a pre-defined volume.
2. Condensate drain hose or pump for directly evacuating moisture outside the cabinet.
3. Internal thermostat/hygrostat for control or ability to interface with cabinet humidity/temperature controller.
4. Lower voltage operation to run off available control power (e.g. 24VDC).
5. More robust construction for continuous operation without maintenance and higher cycling rates.
6. Mounting provisions (e.g. DIN rail, brackets).

Dehumidifiers are typically placed at the bottom and side of a cabinet and the condensate hose is routed through the wall or floor to drain outside. Consideration should be given to making sure air circulates through the dehumidifier, either through internal cabinet fans or by positioning the internal dehumidifier fans.

Dehumidifiers are viewed as an expensive addition to a system but their cost is a small fraction of the total investment in high power (500kW+) systems placed in humid environments and the cost of a humidity induced failure (explosion) is much higher.

## 5.6 Vents

For small, sealed enclosures where it is necessary to equalize pressure, specialized snap-in or screw-in vents are available. These vents incorporate a semi-permeable hydrophobic membrane that allows vapor to pass through while keeping out water droplets and other contamination (Figure 12). It is important to understand that these vents may allow water vapor to pass through so they do not necessarily reduce the absolute humidity. However, they are important in ensuring that a mismatch in pressure does not occur resulting in high relative humidity inside the enclosure.

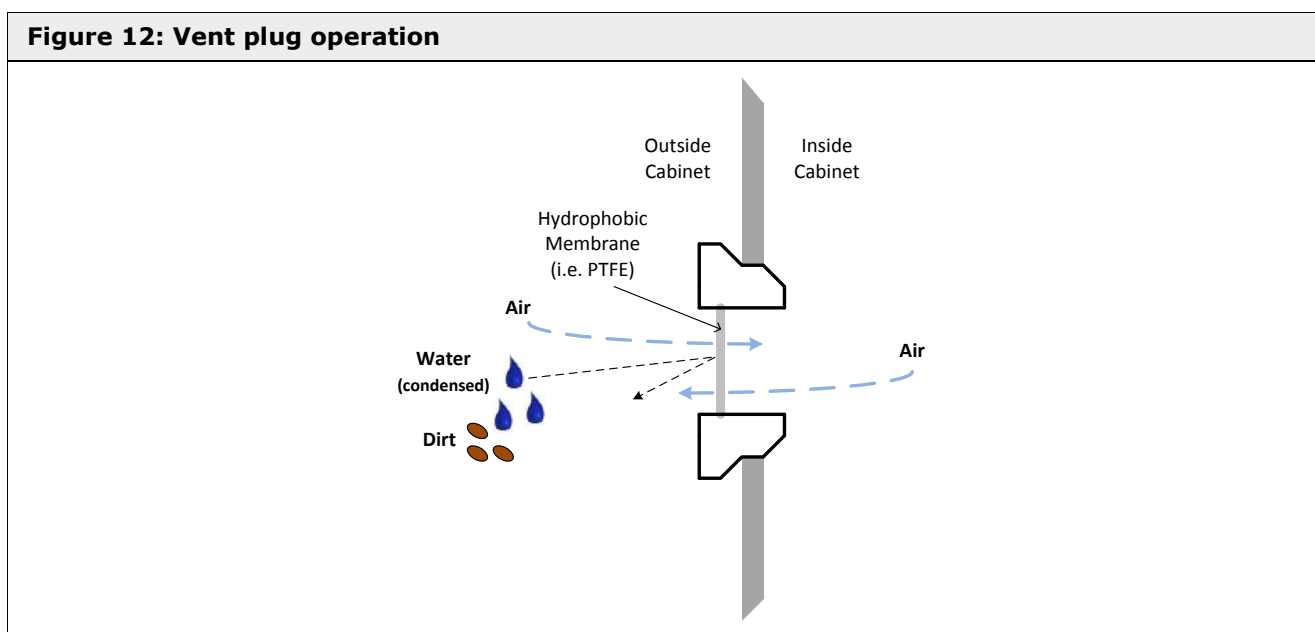

## 5.7 Desiccants

Desiccants are hygroscopic materials that absorb and store moisture from the air. They normally consist of a silica gel (or other natural material such as clay) packaged in a permeable membrane through which moist air can pass. Because they entrap water vapor their capacity is limited and they will eventually become saturated. For this reason desiccants are typically only used during transportation of sealed containers for entrapping residual water vapor. In an open system they will quickly become saturated and lose their effectiveness. Most silica gel desiccants contain some visual indication of the amount of moisture they contain (e.g. blue when dry, pink when moist). Desiccants can be reused by heating them to drive out the entrapped moisture.

## 6. Examples

### 6.1 The ideal sealed cabinet

**Figure 13: Suggested elements for an ideal sealed cabinet design**

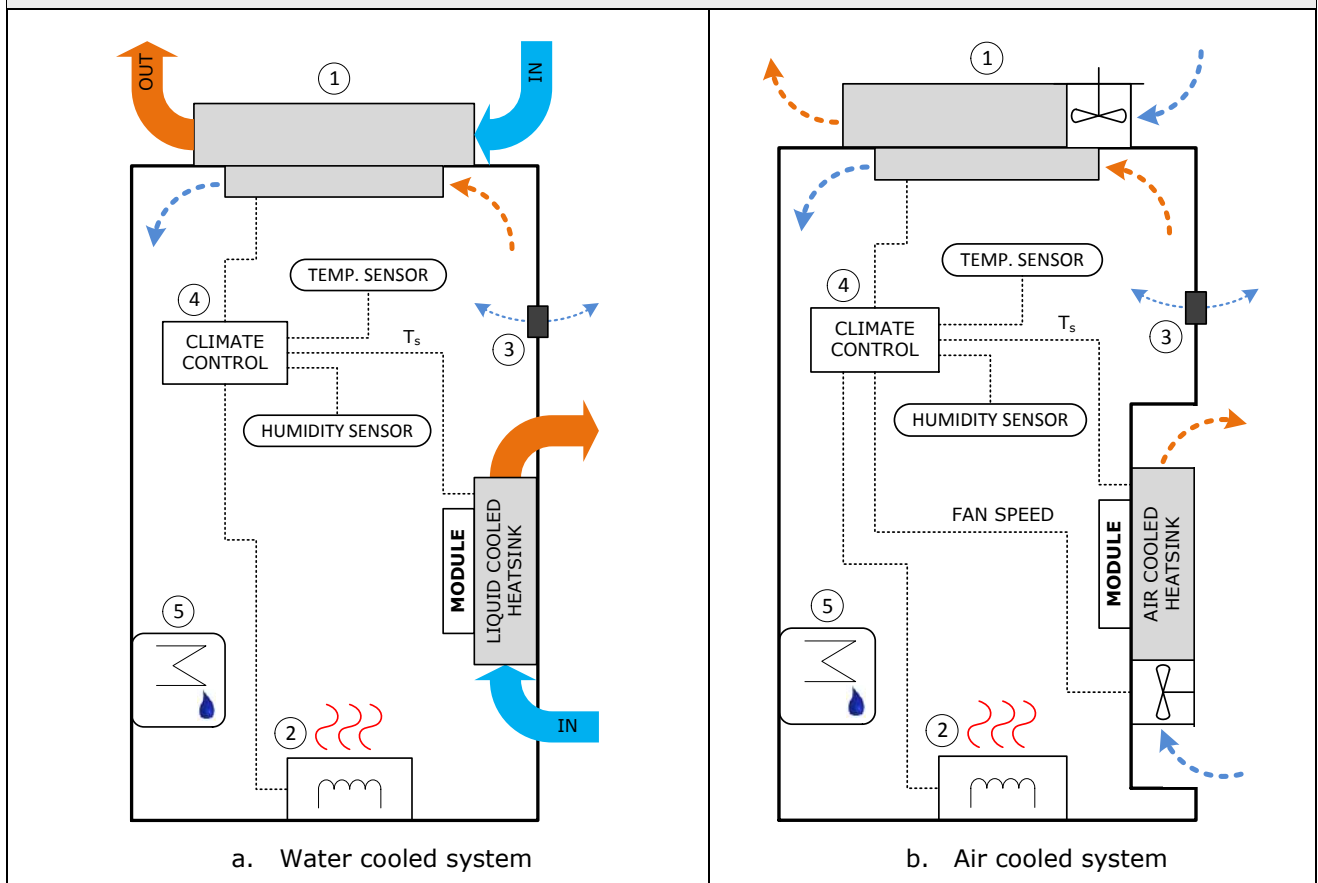

1. **Air-to-water (or air) heat exchanger:** Cools internal air without exchanging internal and external air. Also provides circulation inside cabinet to prevent formation of hot or cold spots.
2. **Heater:** Keeps relative humidity low and maintains minimum operating temperature.
3. **Vent:** Prevents internal air pressure from increasing above external atmospheric pressure.
4. **Climate control:** Control system (e.g. PLC or portion of system controller) to monitor internal humidity, air/heatsink temperature and adjust heater/fans as necessary.
5. **Dehumidifier:** Condenses moisture present in the internal cabinet air and drains it outside.

## 6.2 The ideal open cabinet

**Figure 14: Suggested elements for an ideal open cabinet design**

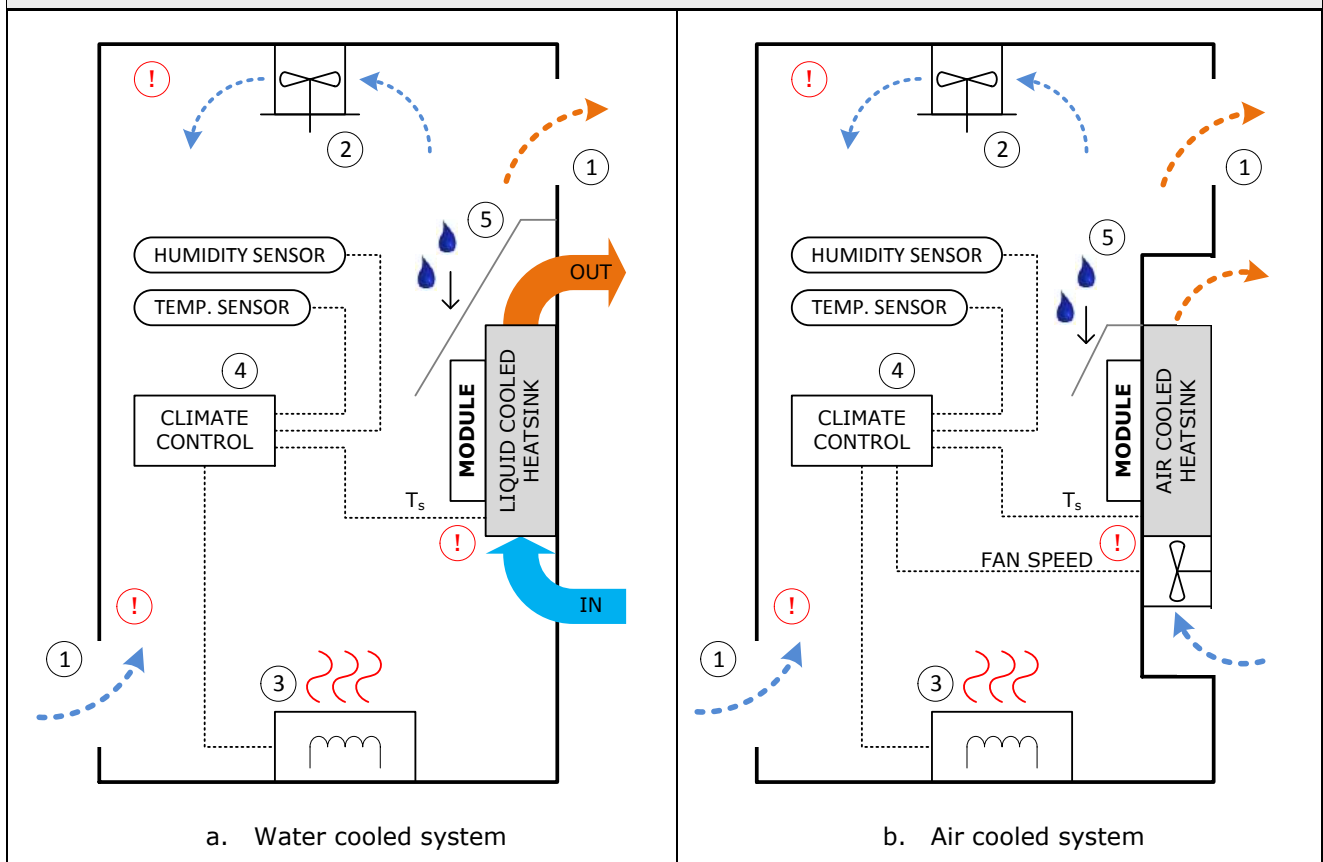

1. **Air inlet and outlet:** Positioned to provide cross flow. May incorporate a fan (with filter) at the inlet or outlet.
2. **Circulating fan:** Provides air movement to minimize formation of hot or cold spots.
3. **Heater:** Keeps relative humidity low and maintains minimum operating temperature. Care must be taken to ensure that all components are heated to the minimum temperature prior to bringing in outside cooling air since some components (e.g. heatsinks) have a large thermal mass and require more time to reach equilibrium.
4. **Climate control:** Control system (e.g. PLC or portion of system controller) to monitor internal humidity, air/heatsink temperature and adjust heater/fans as necessary.
5. **Critical areas (!):** Areas such as exterior cabinet walls, air inlets and heatsinks may be at an increased risk for condensation, particularly when the air inside the cabinet becomes much warmer than the outside air. In severe cases it may be necessary to provide a drip shield to prevent condensation from dripping on electrified parts. In the case of water cooled systems the (cool) inlet should already be below the (warm) outlet to avoid trapping air in heatsinks. This has the added advantage of ensuring that the condensation-prone inlet does not drip directly onto the power module.



It should be noted that in both recommended air-cooled cabinet designs the air channel for the heatsink is separated from the rest of the cabinet (Figure 13b and Figure 14b). All too often the configuration shown in Figure 15 is used, where the entire air cooled assembly is placed inside the cabinet and all components are subjected to the same air as is used to cool the heatsink. This has the following drawbacks:

1. The large volume of air brings in particulate pollution (dust, dirt) that settles on circuit boards and electrical connections, reducing clearance and creepage distances for voltage withstand. Adding inlet filters can help, but these reduce the effective flow rate of the air and become dirty quickly (and are often not serviced regularly or removed entirely by maintenance staff).
2. The possible condensation on heatsinks and air inlets/outlets is now at risk of directly interacting with water-sensitive components (circuit boards, conductors) since they are now in the same compartment as the heatsink.
3. Compared with Figure 14b, the larger volume of air brings in a proportionally larger volume of moisture inside the cabinet, amplifying the risks of condensation at inlets/outlets. Furthermore, the higher flow rate results in higher temperature differentials, possibly pushing certain areas below the dew point.
4. Climate control measures such as heaters are less effective as the volume of air they are trying to regulate is much more dynamic due to the high air flow rate.

**Figure 15: Not recommended cooling configuration**

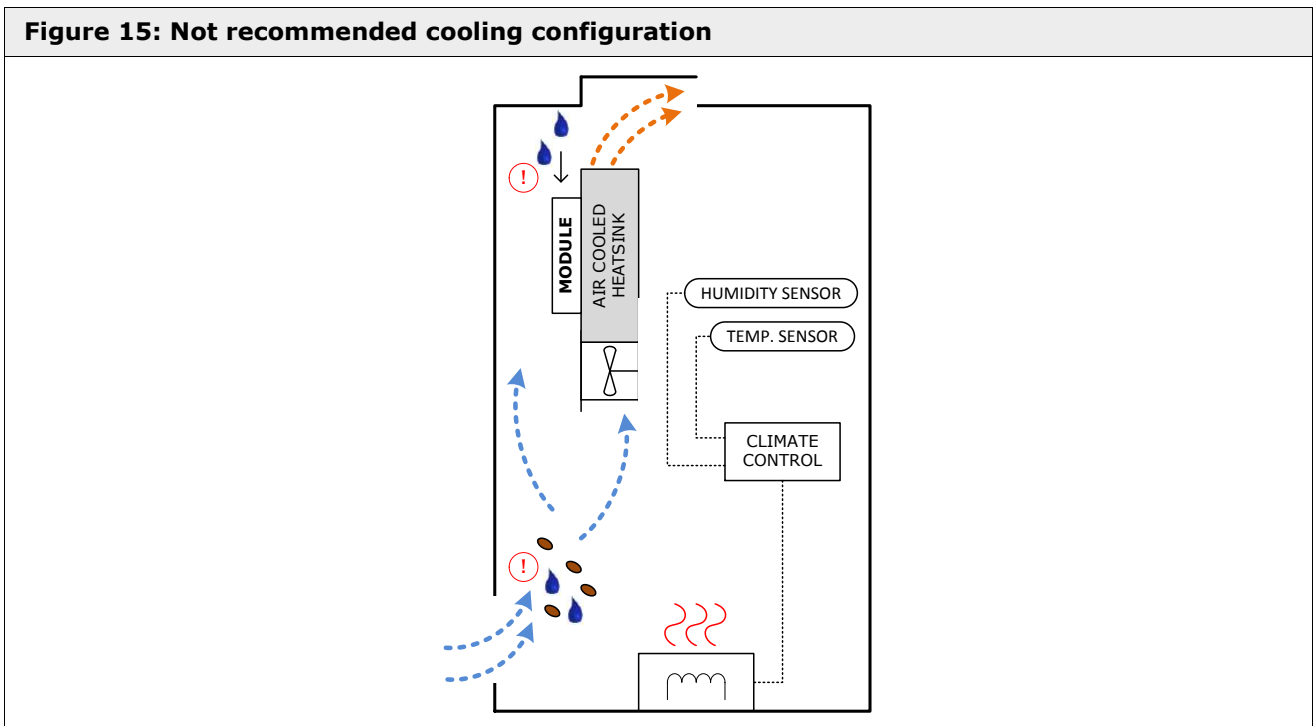

### 6.3 Interpreting the IEC climatogram

The IEC climatogram provides an alternate method of calculating when condensation will occur. If the temperature and relative humidity are known, the absolute humidity value can be fixed and the temperature at which 100% relative humidity occurs (the dew point) can be found.

**Figure 16: Example showing calculation of dew point using the IEC climatogram**

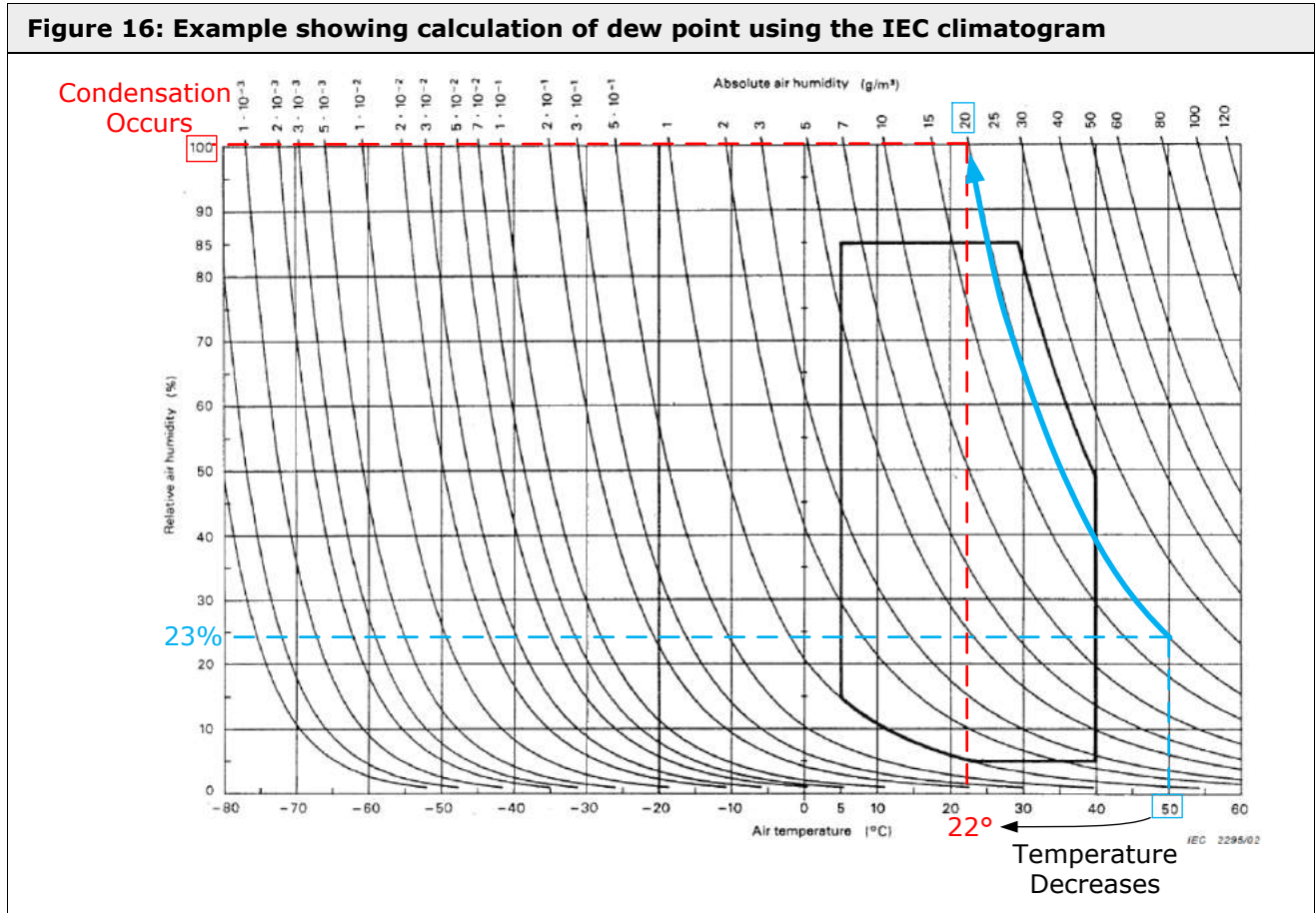

Referring to Figure 16, if the ambient air temperature in a closed system is 50°C and the relative humidity is 23% then the intersection of these two points falls on the 20g/m<sup>3</sup> absolute humidity line (thick blue line). As the temperature decreases this absolute humidity line is followed up to the top of the graph where the relative humidity is at 100% (condensation occurs). The temperature on the x-axis coinciding with this point is the dew point (22°C).

Figure 1: Relationships in a closed system of water vapor/air (variable volume) .....2  
 Figure 2: Chart for determining dew point based on the Magnus equation (altitude = 0m) .....3  
 Figure 3: IEC 60721-3-3 climatogram for class 3K3 and "3K3 modified" for some SEMIKRON products.....4  
 Figure 4: Water molecules diffuse into the silicone gel.....5  
 Figure 5: Water molecules accumulate on surfaces, driven by their dipole characteristic and condensation .6  
 Figure 6: Evidence of liquid having been present on SKiiP heatsink near housing .....6  
 Figure 7: Evidence of liquid having been present on insulation of a DC link assembly .....7  
 Figure 8: Possible temperature disparity due to system operation .....8  
 Figure 9: Two 800W heaters installed in the base of a 2000mm x 800mm x 600mm cabinet.....9  
 Figure 10: Coolant loop with bypass and heater..... 10  
 Figure 11: Results of experiment involving heated coolant to reduce humidity..... 11  
 Figure 12: Vent plug operation ..... 12  
 Figure 13: Suggested elements for an ideal sealed cabinet design ..... 13  
 Figure 14: Suggested elements for an ideal open cabinet design ..... 14  
 Figure 15: Not recommended cooling configuration..... 15  
 Figure 16: Example showing calculation of dew point using the IEC climatogram ..... 16

**Symbols and Terms**

Letter Symbol	Term
RH	Relative humidity

**References**

- [1] www.SEMIKRON.com
- [2] A. Wintrich, U. Nicolai, W. Tursky, T. Reimann, "Application Manual Power Semiconductors", 2nd revised edition, ISLE Verlag 2015, ISBN 978-3-938843-83-3
- [3] Part 3-3: Classification of groups of environmental parameters and their severities – Stationary use at weather protected locations, IEC Standard 60721-3-3 ed. 2.2, 2002
- [4] A. L. Buck, "New Equations for Computing Vapor Pressure and Enhancement Factor", J. App. Meteorology, vol. 20, pp. 1527-1532, Dec. 1981
- [5] Venting, W.L Gore & Associates, Inc. www.gore.com
- [6] Degrees of protection provided by enclosures (IP Code), IEC Standard 60529:1989+A1:1999+A2:2013, 2013
- [7] C. Zorn, N. Kaminski: "Temperature Humidity Bias (THB) Testing on IGBT Modules at High Bias Levels", CIPS 2014, ISBN 978-3-8007-3578-5

**IMPORTANT INFORMATION AND WARNINGS**

The information in this document may not be considered as guarantee or assurance of product characteristics ("Beschaffheitsgarantie"). This document describes only the usual characteristics of products to be expected in typical applications, which may still vary depending on the specific application. Therefore, products must be tested for the respective application in advance. Application adjustments may be necessary. The user of SEMIKRON products is responsible for the safety of their applications embedding SEMIKRON products and must take adequate safety measures to prevent the applications from causing a physical injury, fire or other problem if any of SEMIKRON products become faulty. The user is responsible to make sure that the application design is compliant with all applicable laws, regulations, norms and standards. Except as otherwise explicitly approved by SEMIKRON in a written document signed by authorized representatives of SEMIKRON, SEMIKRON products may not be used in any applications where a failure of the product or any consequences of the use thereof can reasonably be expected to result in personal injury. No representation or warranty is given and no liability is assumed with respect to the accuracy, completeness and/or use of any information herein, including without limitation, warranties of non-infringement of intellectual property rights of any third party. SEMIKRON does not assume any liability arising out of the applications or use of any product; neither does it convey any license under its patent rights, copyrights, trade secrets or other intellectual property rights, nor the rights of others. SEMIKRON makes no representation or warranty of non-infringement or alleged non-infringement of intellectual property rights of any third party which may arise from applications. This document supersedes and replaces all information previously supplied and may be superseded by updates. SEMIKRON reserves the right to make changes.

SEMIKRON INTERNATIONAL GmbH  
 Sigmundstrasse 200, 90431 Nuremberg, Germany  
 Tel: +49 911 6559 6663, Fax: +49 911 6559 262  
 sales@semikron.com, www.semikron.com