

A New High Efficiency Isolated Bi-Directional DC-DC Converter for DC-Bus and Battery-Bank Interface

Xiaoyan Yu
VICOR Corporation
Andover, MA, U.S.A
XYu@vicorpower.com

Paul Yeaman
VICOR Corporation
Andover, MA, U.S.A
PYeamam@vicorpower.com

Abstract: A new bi-directional DC-DC converter is designed and analyzed in this paper. This new topology and its control strategy have completely solved voltage spike issues present in traditional bi-directional DC-DC converters which also have limited power capability and efficiency. This converter can serve as battery bank and DC-bus interface and work in both directions (charging-battery direction and supporting-bus direction) with high efficiency. Operation principles of each block of the circuit and system implementation have been analyzed. Experimental results show high efficiency is able to be achieved in both directions. A 300W in (charging battery) 1500W out (supporting bus) prototype proposed is able to charge battery at 92.9% efficiency (300W) and support bus at 93.6% efficiency (1500W). Higher power level can be easily achieved by reconfiguration or paralleling.

I. INTRODUCTION

As part of the battery manufacturing process, battery cells or battery packs must be tested to ensure that they hold charge and function properly. A standard method of implementing this type of test system consists of a power supply circuit which charges the battery in the correct manner and a load which is used to discharge the battery upon conclusion of the test. In this configuration, the system efficiency is 0%, i.e. all energy used to test the battery is lost.

Using a bi-directional DC-DC converter would enable the recycling of the battery test charge energy by returning this energy to the system. The returned energy could then be used to test subsequent battery cells; yielding a system efficiency that is only a function of charge/discharge conversion losses, with no lost energy due to a dissipative load.

A second application for a high efficiency DC-DC converter exists as an interface to a Battery Back Up system (BBU). Information systems require continued operation of equipment following a power failure. In the event of a power failure, an information system such as datacenters will often require a period of operation on the order of a few minutes following a loss of power prior to the resumption of power from a secondary source such as

a generator. A battery bank is often used to maintain equipment functionality during this time. Since the voltage on the battery bank drops as the bank is discharged, a power conversion interface is required to maintain the correct bus voltage. The battery bank will also require a power source to replenish and maintain lost charge following an event. It would be beneficial from a cost and size standpoint if the battery charge and bus interface functions could be accomplished in a single bi-directional DC-DC converter.

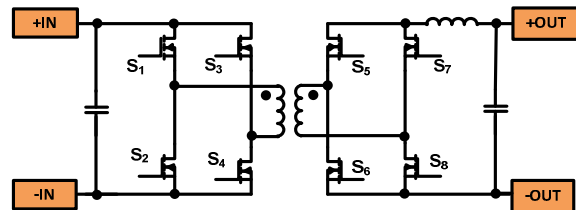

Figure 1. An existing isolated bi-directional DC-DC converter topology

Figure 1 is an existing isolated bi-directional DC-DC converter topology which has been widely used. Input DC voltage is firstly inverted to AC voltage, and then goes through a transformer and rectified to the output DC voltage. This topology is not suitable for high power applications because of the high voltage spike on switching MOSFETs due to the leakage inductance energy storage and discharging. To solve this issue, many derivations of this topology have been developed [1-9]. However, most of these derivations were looking into decreasing this voltage spike through snubber or clamp circuits, which are improvements but cannot fundamentally solve this issue.

A new bi-directional DC-DC converter is designed and analyzed in this paper. Because it is bi-directional, it does not require another DC-DC converter or AC-DC converter to charge the battery. Battery backup system application is used in this paper for the control of this converter.

II. A NEW HIGH EFFICIENCY ISOLATED BI-DIRECTIONAL DC-DC CONVERTER

Figure 2 shows the topology of this new isolated bi-directional DC-DC converter. It includes three basic blocks: block 1, 2 and 3. Block 2 provides isolation and also a fixed ratio step down / up between its input and output voltages. It is bi-directional and current can flow both ways. Block 1 and 3 provide accurate regulation. They are identical blocks, except input and output voltages are in opposite directions. For block 1, the battery is in the output side. For block 3, the bus is in the output side.

1) Block 2

The function of Block 2 is to provide isolation and fixed ratio step up or down. By adding a small capacitor to the transformer, the natural resonant frequency of this small capacitor and the leakage inductor of the transformer can be used to provide zero current switching [10-12]. The natural resonant

frequency of the primary side current is used so that MOSFETs switch at the zero crossing points of its resonant portion. S_5, S_6, S_7 and S_8 always turn on and off when the resonant current reaches zero. As S_5 and S_7 turn on (during t_1 through t_2), the primary side resonant current I_p flows as a sine wave, until it reaches zero. Then S_6 and S_8 turn on and the primary side resonant current I_p flows in the opposite direction, still with a sine wave shape, as shown during t_2 through t_3 . As shown in figure 3, the same switching sequence can lead into both direction operations, thus making this circuit naturally bi-directional.

Because the switching loss in this converter is approximately zero, this converter is capable of operating at a very high switching frequency, up to several MHz, which enables super high power density. With full zero-current-switching (ZCS) on secondary and partial ZCS on the primary (the error is due to the magnetizing current, and zero-voltage-

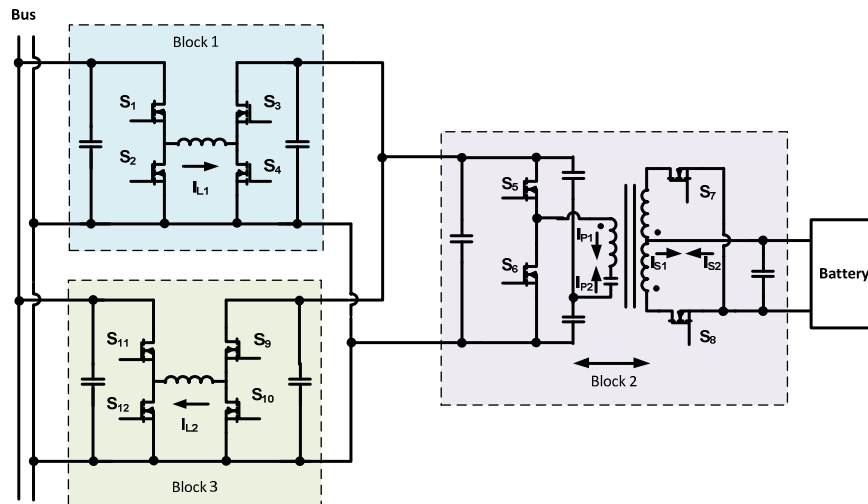

Figure 2. Topology of this new isolated bi-directional DC-DC converter

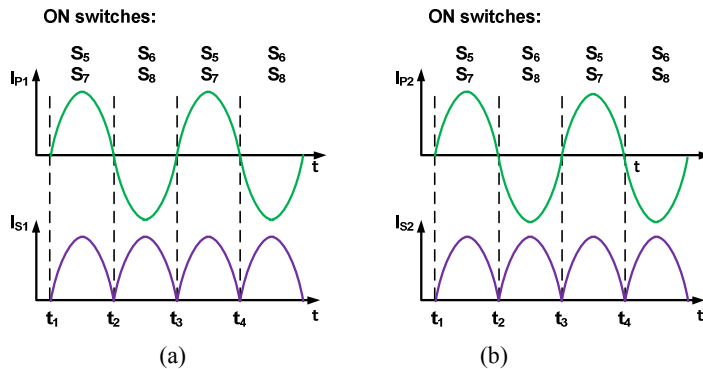

Figure 3. Block 2: Primary and secondary resonant current flows bi-directionally:
(a) charging-battery direction; (b) supporting-bus direction

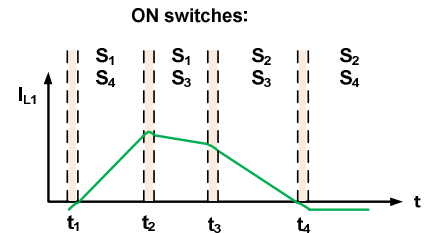

Figure 4. Block 1: current flowing through the inductor with ZVS intervals

switching (ZVS) on the primary side has been used to make the switching loss negligible), very high efficiency can also be achieved.

Since Block 2 uses resonance to achieve zero current switching, the high voltage spike issue on switching MOSFETs is effectively solved. Other topologies in [1-9] can only offer improvements in reducing voltage spike amplitude. The resonant frequency of Block 2 can go as high as several MHz. Thus block 2 can achieve very high power density with very high efficiency.

2) Block 1 / Block 3

Block 1 / Block 3 provide precise regulation. They are identical blocks but in opposite directions, to provide bi-directional operation in the system level. Use Block 1 as an example, as shown in figure 4, during the first stage, S_1 and S_4 are on, and the current flowing through the inductor I_L increases at a speed proportional to V_{in} . Then, S_3 turns on, S_4 turns off, and move to the second stage; I_L could be flat or decrease/increase depending on the difference between input and output voltage. Then, S_2 turns on, S_1 turns off, and move to the third stage; I_L decreases at a speed proportional to V_{out} . Then, S_4 turns on, S_3 turns off, and move to the fourth stage; a slightly negative current goes through the inductor. During the transition, the zero-voltage-switching buck boost controller is used to enable zero voltage transitions [12-13].

High efficiency and high power density can also be achieved in block 1 / block 3, due to the ZVS switching.

A simple control method for this converter in this application is: set the regulated V_{out} of block 3 to a relatively low bus voltage, which is less than the normal bus voltage most of time, but is still sufficient to support the bus load. In this configuration, for most of time, the bus voltage is higher than the regulated V_{out} of block 3, so block 3 only consumes no load power dissipation. In the meantime, for most of time, bus charges battery through block 1 and 2. When bus voltage suddenly vanishes, block 3 processes power immediately, and current flows through block 2 and 3 to support the bus.

This configuration provides great advantage in getting high efficiency and high power density bi-directionally, especially for this bus-battery interface application.

It requires different power levels for battery charge and discharge modes. When it is in battery-charge mode, the required power level should be much lower than the supporting-bus mode. Actually it is better to limit the charging power below some

level to ensure safety. In this configuration, n of Block 3 can be put in parallels to achieve the bus power level; while l or m (m can be significantly less than n) of Block 1 should be enough to provide charging power. Thus, although block 1 or 3 is not bi-directional individually, they work together to cover both directions, with a total size / power dissipation close to n of block 1. The advantage of this configuration is significant as the power ratio between supporting-bus and charging-battery is high.

III. EXPERIMENTAL RESULTS

Use 48V as the bus voltage, 12V as the battery voltage. Thus the step down ratio for block 2 needs to be designed as 4:1.

When $V_{in}=48V$, for a 300W, 4:1 ratio module of block 2, the tested efficiency is above 96% after the load is over 50%, and peaks at 96.2%. When load is less than 50%, the efficiency drops, but it is still able to achieve 85.5% efficiency at 10% load. All these tests are based on room temperature condition. An efficiency matrix test at different line and load conditions are shown in figure 5 (a). The input voltage is designed to be 26-55V, so battery voltage of 6.5-13.75V can support the bus in the reverse direction. This wide range would enable more configurations of batteries, and more importantly, enable the battery to support bus for a longer period.

Figure 5 (b) are the experimental efficiency test results of a block 2 module at the direction of supporting bus, which is defined as the reverse direction in this paper. A deep cycle marine lead acid 12V battery (part number of 24DC-1, reserve capacity of 140 minutes, cold and marine cranking amps over 500 amperes) is used in this experiment to support the bus through a block 2 module. Because the battery terminal voltage droops as the supply current increases, so the V_{in} droops from 11.7V ($I_{out}=0.6A*4$) to 10.9V ($I_{out}=6.3A*4$). The peak efficiency is 96.9%. Notice that the efficiency of the supporting-bus direction is even higher than the charging-battery direction, which is beneficial for this application, since in reverse condition, battery needs to support the bus with a much higher power level than the charging-battery direction. A higher efficiency in the supporting-bus direction would simplify thermal management task for this high power application.

For a 500W block 1 / block 3 module, the experimental efficiency test results are shown in figure 6. The peak efficiency is 97.3%.

These modules could be disabled / enabled through control circuit. The disabled power dissipation is significantly less than no load power

dissipation. At 25°C, with the nominal input voltage of 48V, a 500W block 3 or block 1 module has a typical disabled power dissipation of 0.78W and a typical no load power dissipation of 2.4W; a 300W 4:1 ratio block 2 module has a typical disabled power dissipation of 0.04W and a typical no load power dissipation of 5.3W.

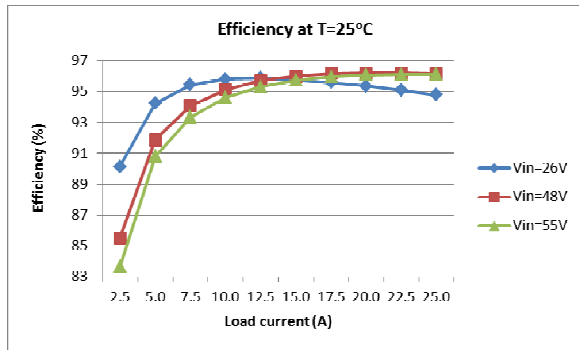

(a)

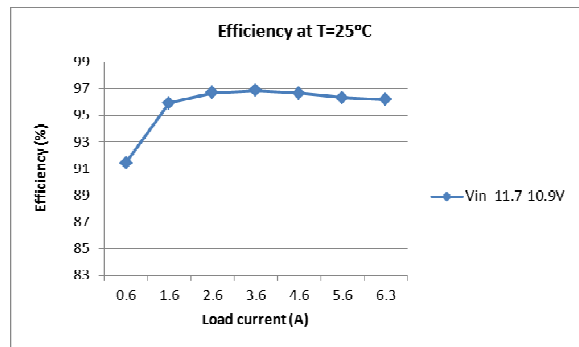

(b)

Figure 5. Experimental results of efficiency for a block 2 module (300W, 4:1 ratio) at the direction of: (a) charging battery (b) supporting bus.

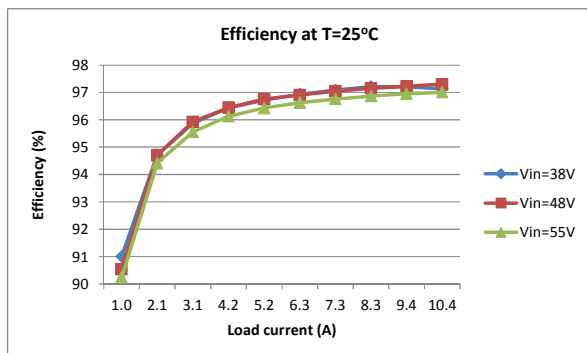

Figure 6. Experimental results of efficiency for a block 1 / block 3 module (500W, room temperature)

IV. SYSTEM IMPLEMENTATION

A 7"× 9" PCB prototype of this bi-directional DC-DC converter has been built for this application, as shown in figure 7, with 3 of block 3 modules (500W per module) in parallels, and 5 of block 2 modules (300W per module) in parallels.

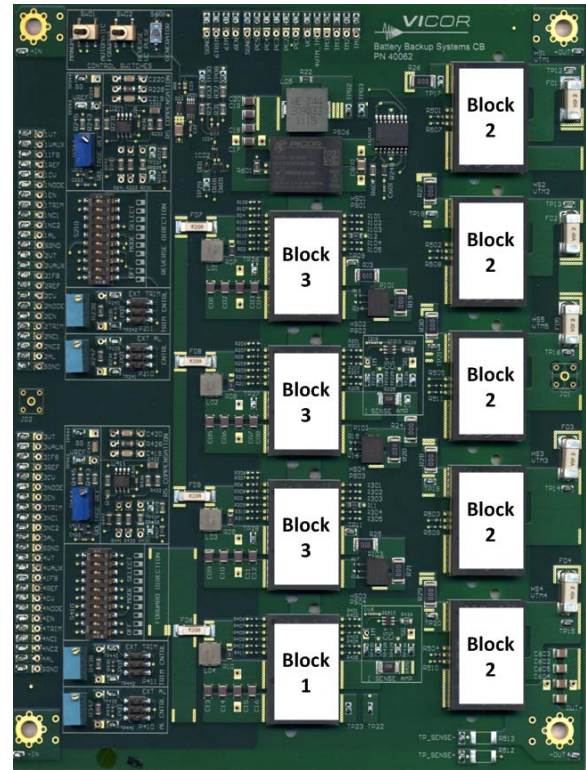

Figure 7. System implementation.

A simple paralleling of modules and put them together as the topology in figure 2, would allow this converter works. Set the regulated V_{out} of the block 3 modules to a relatively low bus voltage, which is less than normal bus voltage most of time, but is still sufficient to support the bus load. In this way, no more system control circuit is necessary. All 5 block 2 modules can process power immediately once it is in supporting-bus mode.

The disadvantage of this configuration is: all the modules remain active all the time and some of them consumes light load / no load power dissipation during most of their operation time.

To save this light load / no load power dissipation, modules can be disabled during the time they do not need to remain active.

In case bus voltage vanishes, some modules need to recover from disabled mode to enabled mode. During this time period, the bus voltage is supported

by capacitors. After ensuring enough capacitance added to the bus to support over module fast restart period, system level control circuit in this board can be used to disable / enable modules to save from unnecessary power dissipation.

In the charging-battery direction, 4 of the block 2 modules can be disabled, and all the 3 block 3 modules can be disabled, which gives a charging-battery power of 300W.

In the supporting-bus direction, the block 1 module can be disabled, which gives a supporting-bus power of 1500W.

This system is capable of charging battery at 300W/25A, and supporting 48V bus at 1500W/31A in this configuration. With the battery reserve capacity of 140 minutes, it will be charged from completely discharged to fully charged within 2.3 hours, and then is able to support the bus (1500W load) for 28 minutes. Higher power level can be easily achieved by reconfiguration or paralleling.

Use 97.3% as the block 1 / block 3 module efficiency, and 96.2% as the block 2 module efficiency in both forward and reverse mode. Use 0.78W as the block 1 / block 3 module disabled power dissipation, and 0.04W as the block 2 module disabled power dissipation.

Thus in the charging-battery mode, the peak efficiency is:

$$\frac{300}{300 / (0.962 * 0.973) + 0.04 * 4 + 0.78 * 3} = 92.9\% ;$$

In the supporting-bus mode, the peak efficiency is:

$$\frac{1500}{1500 / (0.962 * 0.973) + 0.78} = 93.6\%$$

V. CONCLUSIONS

A new bi-directional DC-DC converter is designed and analyzed in this paper. It can be used to interface battery bank and DC-bus bi-directionally (charging-battery direction and supporting-bus direction). Operation principles of each block of the circuit and system implementation have been analyzed. Experimental results show it is able to achieve high efficiency in both directions. A prototype of 300W in (charging battery) 1500W out (supporting bus) bi-directional DC-DC converter has been built for this application. With a lead acid battery reserve capacity of 140 minutes, it will be charged from completely discharged to fully charged within 2.3 hours, and then is able to support the bus (1500W load) for 28 minutes. With the system control circuits on board, this prototype is able to

charge battery at 92.9% efficiency (300W) and support bus at 93.6% efficiency (1500W). Higher power level can be easily achieved by re-configuration or paralleling.

I. ACKNOWLEDGMENT

The authors would like to acknowledge and extend our heartfelt gratitude to Mr. Joseph Aguilar in Vicor Corporation for the nice discussion and supporting this work.

REFERENCES

- [1] Review of Non-isolated Bi-directional DC-DC Converters for Plug-in Hybrid Electric Vehicle Charge Station Application at Municipal Parking Decks
- [2] Pike Research Report, "The Global Outlook for PHEVs: Business Issues, Technology Issues, Key Players, and Market Forecasts," third quarter, 2009
- [3] Lisheng Shi, A. Meintz, M. Ferdowsi, "Single-phase bidirectional ACDC converters for plug-in hybrid electric vehicle applications," in IEEE 2008 Vehicle Power and Propulsion Conference, 2008.
- [4] Y. Gurkaynak, A. Khaligh, "Control and Power Management of a Grid Connected Residential Photovoltaic System with Plug-in Electric Vehicle (PHEV) Load," in IEEE 2009 Applied Power Electronics Conference, 2009, pp.2086-2091.
- [5] V. Marano, G. Rizzoni, "Energy and Economic Evaluation of PHEVs and their Interaction with Renewable Energy Sources and the Power Grid," in IEEE 2008 Proceedings of the International Conference on Vehicular Electronics and Safety, 2008, pp. 22-24.
- [6] S. D. Jenkins, J.R. Rossmair, M. Ferdowsi, "Utilization and Effect of Plug-in Hybrid Electric Vehicles in the United States Power Grid," in IEEE 2008 Vehicle Power and Propulsion Conference, 2008.
- [7] P. Kulshrestha, L. Wang, M.Y. Chow, S. Lukic, "Intelligent Energy Management System Simulator for PHEVs at Municipal Parking Deck in a Smart Grid Environment", in proc IEEE Power and Energy Society General Meeting Conference, 2009.
- [8] M. Bojrup, P. Karlsson, M. Alakula, B. Simonsson, "A dual purpose battery charger for electric vehicles," in IEEE 1998 Power Electronics Specialists Conference, 1998, vol.1, pp.565-570.
- [9] M. Ortúzar, J. Dixon, J. Moreno, "Ultracapacitor-Based Auxiliary Energy System for an Electric Vehicle: Implementation and Evaluation" in IEEE Transactions on Industrial Electronics, vol.54, issue 4, Aug.2007, pp.2147-2156
- [10] M. Salato, "The Sine Amplitude Converter Topology Provides Superior Efficiency and Power Density in Intermediate Bus Architecture Applications", Vicor Corporation white paper.
- [11] P. Vinciarelli, "Factorized power architecture with point of load sine amplitude converters." U.S. Patents: 6,930,893, issued Aug 16, 2005
- [12] X.Yu, M. Salato, "An Optimal Minimum-Component DC-DC Converter Input Filter Design and Its Stability Analysis", IEEE Trans. on Power Electronics, vol. 29, pp. 829-840, Feb 2014.
- [13] P. Vinciarelli, "Buck-boost DC-DC switching power conversion", U.S. Patents: 6,788,033, issued Sep 7, 2004