

# How Vicor Power Components Enable Power Averaging

Dave Berry  
Principal Applications Engineer  
September 2016



Power systems generally fit into one of two types: those that need to deliver a continuous output, and those where the energy is driven in short bursts. Using traditional design techniques, pulse load systems are configured based on the maximum output power required. For example, if the load is 3 kW and is on for 1 ms and off for 5 ms, the supply is configured for 3 kW even though the average power in this case is only 500 W.

This approach presents several problems. Because conventional power design techniques require the system to be designed around the maximum required power, the size, weight and cost of the system is determined by the peak, rather than the average power requirement. As system power levels increase, many power designers are finding it difficult to stay within space and weight constraints. Support circuitry, such as bypass caps, heat sinks, and system fans, takes up system real estate, exacerbating the problem and making it even more difficult to meet the application’s physical requirements. Designing the power system for the average power can be a better alternative.

## Power Averaging

One solution for applications where the load is only on for a short duration, and is repetitive, is to use a current limiting converter and a capacitor to supply peak power needs. When configuring such a power system, the designer must take into account the current limit, power limit, and stability of the power supply as well as sizing the capacitor properly to keep the voltage drop at the load within its tolerances. Applications such as pulsed amplifiers, flashing LED lights, and reclosures can take advantage of power averaging to reduce cost, space, and weight within the system.

Figure 1  
Power averaging configuration

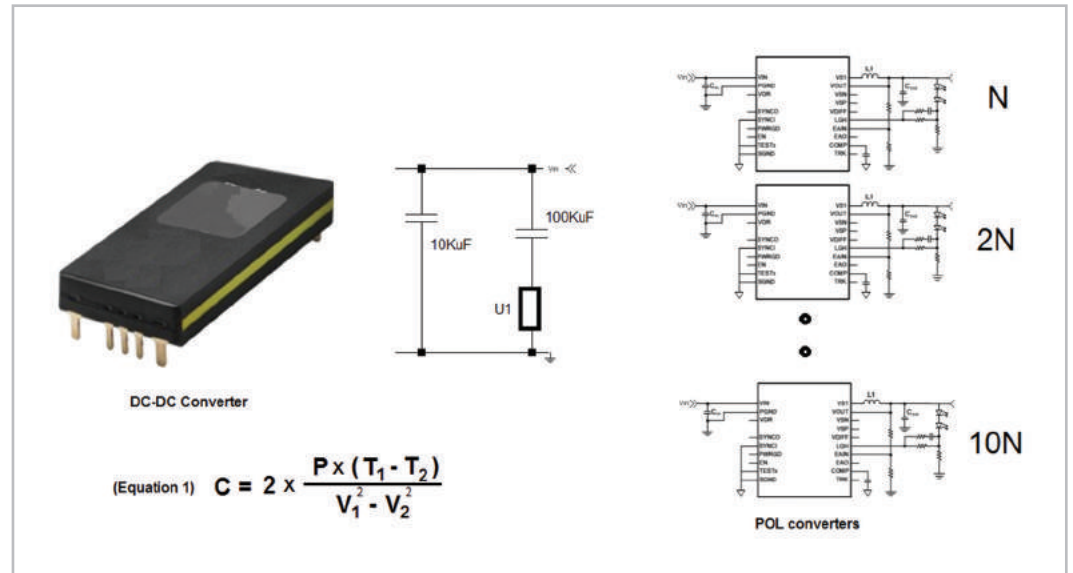

---

Power averaging configurations are very effective when the load can tolerate a wide input voltage range. This is typically the case where the load is another regulating device (typically a PoL converter) or several of these regulating devices.

When the POL or load demands power, the capacitor will deliver a greater portion of the load current because the DC converter will go into current limit feeding the capacitor and the load. As the capacitor delivers the POL or load current, its voltage will begin to fall. The capacitor must be sized so that the voltage across the capacitor stays within the input voltage range of the POL converter.

To minimize the capacitance needed the designer can charge the capacitor to the POL's maximum input voltage and allow the power draw over the power duration to operate the capacitor down to the POL's minimum input voltage.

### **Operation of Current Limiters in Pulsed Applications**

DC-DC converters are typically designed to regulate voltage up to a maximum power level and therefore have a maximum current and power rating. If the load tries to draw more than the rated current from the supply, the supply will typically go into a current limiting mode that will either fold back the output voltage of the supply or the supply will shut down and restart.

The current limit is typically set just above the maximum rated current so, at the voltage set point of the converter, full power delivery can be achieved. A converter rated for 500 W at 48 VDC will have a maximum continuous current rating of 500 W/48 VDC or 10.4 A. The current limiting feature, however, may not start until the output current is at 13 A. Current limiting is typically designed for load faults, where the converter will see current limit only a few times in its life. If the converter isn't designed to go into current limit as a normal mode of operation, you can stress components within the converter and shorten the life of the power system.

If the load draws more than the maximum current but below the current limit at the voltage set point, then you can overpower the supply and cause eventual power system failure. So a 500 watt converter at 48 VDC with a current limit set at 13 A will be overpowered at up to 624 W before current limiting starts.

### **Dealing with Large Bulk Capacitance**

The large bulk capacitance used in power averaging applications can cause many complications for the DC power system. At turn-on the larger capacitor, which in many cases can be in the thousands of microfarads, can draw the DC supply into current limit. With the potential problems associated with built-in current limiter, frequently an external current limiting circuit is required to keep the supply within its maximum current and maximum power ratings.

Power designers can pre-charge the capacitor or add series resistance that limits the current at startup, which can be shorted out once the external current limiting circuit is active. Pre-charging and current limiting circuits can be complex and they take up valuable board real estate. The external current limiting circuits must also be fast enough to catch an over-current event. This can be challenging because even a few switching cycles can cause an over-current event.

Once the DC supply successfully powers up, the power system must be stable. With some DC-DC converters, the large capacitor can destabilize the voltage control loop, which can cause supply or system failure. The power designer can overcome this potential stability issue if he has access to the control loop of the power system, but this requires complex and time-consuming engineering work.

## DCMs are Designed for Highly Capacitive Loads

The peripheral circuitry can become very complex if the power converter isn't designed to handle a large capacitor at its output. Vicor DC converter modules (DCMs), however, are designed to handle large amounts of capacitance at their outputs, and can operate within their maximum current rating and power rating even when driving capacitance values as large as 10 KuF. Even larger capacitance can be handled if it is switched in during start up. The DCM has a safe current limiting feature which means it can safely operate at the voltage set point of the module because the DCM can deliver more than its rated power for short durations.

At startup, the DCM will drive the capacitor up to voltage while staying within its safe operating area. Once the capacitor is charged, the control loop of the converter is designed to be stable during normal operation.

If the application is designed for power averaging, the initial power burst into the downstream POLs will be greater than the converter's capability. The POL input current will be delivered from the voltage source that has the largest potential. Due to the ESR of the capacitor the converter's output can have the larger potential and will deliver the initial surge of current until its output drops because of current limit. DCMs are designed to handle this surge current until its internal current limit takes over. Once the DCM's voltage drops, the current demand will then be satisfied by the capacitor. The capacitor can be sized to deliver much more current than the DC converter module. Once the POL or load current demand is over, the DC converter has to recharge the capacitor to its initial voltage so it can be ready for the next current demand.

Figure 2  
Lab results for power averaging configuration

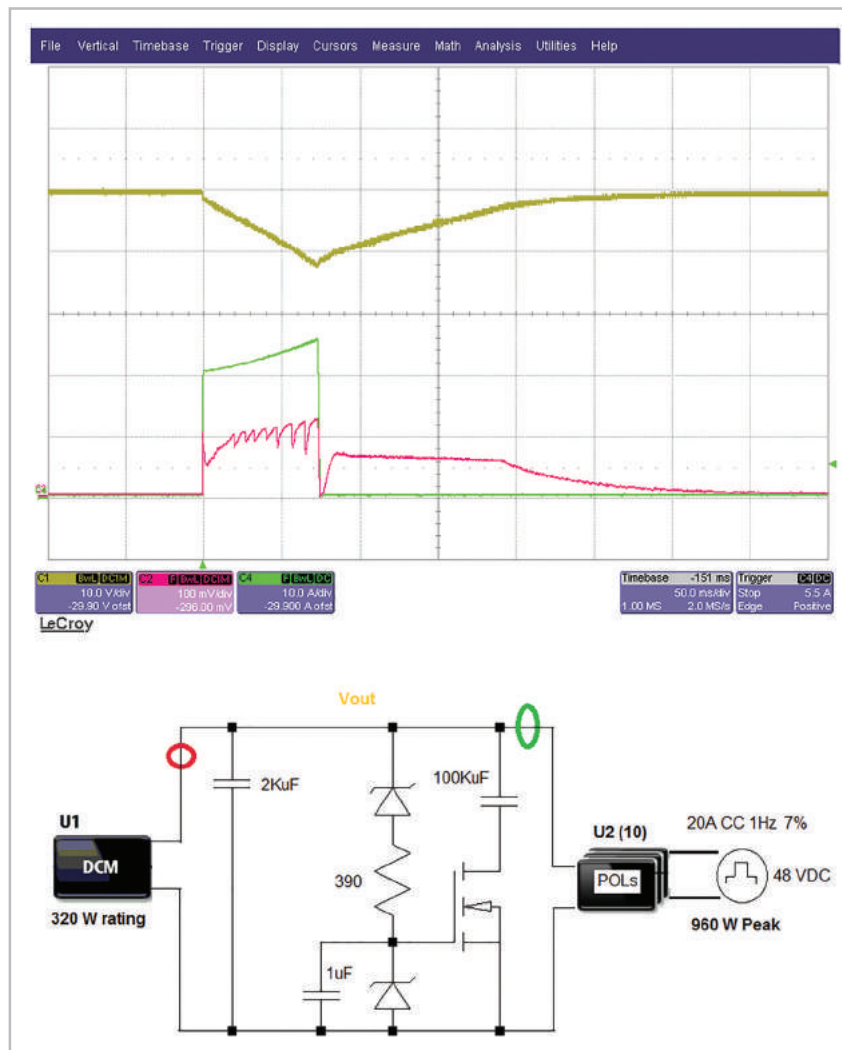

---

Figure 2 shows a scope plot and block diagram of a power system designed for power averaging. In this example, the DC converter module has its output set to 50 VDC and the converter module is rated for 320 W of continuous power. The downstream POL converters are supplying a total 20 A at 48 VDC or 960 W of load power. The load frequency is 1 Hz and the duty cycle is 7% so the load is on for 70 ms. When the POLs begin to deliver power to the load, they draw energy from the 100  $\mu$ F capacitor and the DCM. The DCM will go into protective current limit and the capacitor will supply the bulk of the power with the DCM in current limit. After the load demand is complete, the DCM will recharge the capacitor to its initial voltage.

## Conclusion

Supplies configured for power averaging are very effective for reducing the size, weight, and cost of power systems where the load is on for a short periodic duration. The support circuitry can be minimized if the DC converter module is designed to operate safely within its current limit and power limit maximums. Sizing the power system for the average power also helps eliminate the support circuitry and hardware needed for power systems sized for continuous peak power delivery. This saves also helps the designer stay within the system space and weight constraints.