

The Adaptive Cell Converter Topology Enables Constant Efficiency Over Universal Input AC Line in Front-End, High-Density Power Factor Correction Applications



Written by: Maurizio Salato
 Director, Systems Engineering
 November 2012

Introduction

The Adaptive Cell™ topology is a unique, proprietary architecture at the heart of Vicor's high performance PFM® AC-DC products. Power Factor Corrected AC rectification has been addressed in a variety of ways over the past three decades; however, the wide variation of worldwide AC line has imposed significant design trade-offs to front-end converters that accept 85 V_{RMS} to 264 V_{RMS} at their input. With the exception of portable power adapters, the vast majority of electronic equipment is installed in specific geographies and supplied with a particular single phase AC main, which is usually guaranteed within a ±20% band around one of the three most common nominal values: 100, 120 and 230 V_{RMS}. This paper will explain how the Vicor PFM converter represents a breakthrough in AC front-end power factor correction by analyzing the converter structure at three different levels of details: in a classic bottom-up approach, three different “magnification factors” will be applied to the same structure. This will allow a comprehensive description and explain how state-of-the-art performance can be achieved.

“Classic” Power Factor Correction and Rationale for Adaptive Cells

Power factor correction controls have traditionally been designed with reference to the boost converter topology. The simplest way to shape the converter input current similar to the line voltage is by implementing a multiplier stage within a cascade control loop, as shown in Figure 1. The line voltage is sensed and multiplied by the current reference provided by the outer voltage loop. The same line voltage input is used in feed-forward fashion in order to maintain constant loop bandwidth across the line voltage range. The result is that the output voltage is regulated by varying the amplitude of the input current, which closely follows the shape of the line voltage.

Improved techniques, for example, One-Cycle Control (OCC) shown in Figure 2, rely on improved line voltage sensing mechanism. In this case, the inductor acts as an indirect line voltage sensing element, having its current slope proportional to the line voltage. This, together with the resettable integrator block, avoids the need for feed-forward compensation of current loop, like in the multiplier based designs.

It is evident though, that AC line variation exhibits a trade-off relationship with two very important design aspects:

1. Control loops stability: Maintaining a steady bandwidth across an instantaneous input voltage range that spans from 0 V to 375 V requires advanced control techniques.
2. Power semiconductors and magnetic components ratings: Providing the same power to the load requires switches, diodes and magnetic devices to be designed for worst case application scenarios (maximum voltage, maximum current), which are never concurrently applied under any given condition.

The same considerations apply to any isolated topology (i.e. forward or flyback converters), with the additional burden of further component de-rating due to topological states where various voltage (or current) sources instantaneously add up and apply to specific devices.

Adaptive Cell, Double Clamp ZVS Converter

To overcome the limits explained above, Vicor developed a new converter topology called Double Clamp ZVS and a new dynamic converter architecture, called Adaptive Cell. Let's analyze how they work and how they comprehensively address the key issues of AC-DC power conversion.

The Double Clamp, Zero-Voltage Switching Converter (DC-ZVS) consists of a full bridge primary and a single ended rectifier secondary, as shown in Figure 3. Just like a boost PFC, an inductor acts as the primary energy storage element; however, two windings with different numbers of turns are coupled on the same core. This particular structure operates in discontinuous conduction mode and has three topological states, shown in Figure 4. During the first state, the inductor stores energy from the utility line. During the second state, the accumulated energy is transferred to the load by the secondary stage. The third state allows the inductor to store some reactive energy. Capacitor CCL also acts as storage element, holding primary reflected output voltage. These two energy storage elements (hence the name "double clamp"), together with proper switch timing, enable every transition to happen at either zero voltage, zero current or both (hence the name "zero-voltage-switching"), therefore avoiding switching losses and enabling very high switching frequency. More importantly, this topology enables switches with lower voltage ratings, for the following reasons:

1. the resonant transitions guarantee absence of transient overvoltage
2. the reverse voltage applied to the primary switches is limited to and, in most cases, is lower than the peak input voltage

Lowering the voltage requirement of power switches enables silicon technologies with higher figure of merit: lower conduction losses, lower driving currents (due to periodic switching charge handling), and higher density. Some passive components also benefit from reduced voltage requirements, as well as increased operating frequency. All these advantages together enable isolated converters with power density in excess of 700 W/inch³ (43 W/cm³). While these attributes establish the function of efficient DC-DC conversion, the wide input voltage variation is still present and needs to be addressed one level above the converter topology.

Adaptive Cell is a dynamic architecture which manages two DC-ZVS converters, maintaining operation at their highest efficiency, despite the wide input line voltage variation. A two-cells block diagram in Figure 5, shows two identical converters, whose output stages are permanently connected in parallel, while the primary stages can be configured either in series or in parallel to the input line through switches T₁, T₂ and T₃. The two coupled inductors share the same magnetic core; and the two primary powertrains are managed by the same modulation control. This ensures the proper symmetry among cells and guarantees power sharing in any given condition. Figure 6 shows input current and output voltage waveforms for a complete sweep of rectified line voltage. During the lower half of the range, from 85 V_{RMS} to 145 V_{RMS}, T₁ and T₃ are closed, while T₂ is open. Primaries are configured in parallel, and they divide the total input current while sharing the same input voltage. Effective duty cycle control is applied in order to shape the input current according to power factor corrected front-end requirements. However, note that an effective modulation angle is applied (more on this later in the paper).

When input voltage exceeds the 145 V_{RMS} threshold (with some hysteresis) and up to the higher limit of 264 V_{RMS}, T₁ and T₃ open, while T₂ is closed. Primaries are now connected in series, and they effectively divide the line voltage while sharing the input current. Duty cycle control is applied in order to obtain power factor correction as in the previous state; however, due to Adaptive Cell, the two line ranges are completely equivalent with respect to each primary stage of the two converters. This brings several

different benefits to the converters' modulation control: duty cycle range, voltage range, and current range – the two cells configurations allow identical converter operations across each half of the input line range. The overhead represented by the three configuration switches (T_1 , T_2 and T_3) is easily absorbed by the advantages in size of the two cells converters, in which both input current and voltage range requirements are reduced by 50% compared to single cell architecture. Configuration switches can be optimized for conduction, as they are not expected to continuously reconfigure in field operations, and are a modest toll compared to the significant advantage brought to the converters' powertrains and controls.

Vicor PFM Module Features and Benefits

The DC-ZVS engine and the Adaptive Cell architecture enable several significant advantages at both product and system level.

1. Converter efficiency minimally affected by input line voltage: This most notable advantage for powertrain design also applies to thermal design, which can be optimized on any AC main within the universal AC range. Thermal system requirements do not change with low input voltages, thus enabling significant savings.
2. Use of reduced rating, higher figure of merit devices and components: While this has a direct impact on overall efficiency, it also translates to reduced thermal gradients which, in turn, implies robustness, higher reliability and maximum system availability.
3. High frequency, Zero-Voltage Switching: The clear advantage in density extends to output voltage switching ripple. The PFM[®] module operates above 1 MHz, enabling low-cost, high-density filters. Moreover, zero-voltage transitions reduce the harmonic spectrum of the noise, which is centered on the switching frequency, to which filters can be effectively tuned.
4. Symmetric line current conduction angle: As shown in Figure 6, line current is always in phase with line voltage and shaped accordingly. However, a symmetric modulation angle is introduced in order to avoid converter operations when very low power is available. The PFM module is able to effectively source 97% of the available power (given voltage and current peaks), avoiding operations near line zero crossing where processed power is inherently wasted in losses and does not significantly contribute to the power made available to the load.
5. Optimal line current shaping: Through proprietary techniques, input line current shape has a reduced dependency on instantaneous input line voltage. Current absorbed by the PFM module is therefore less susceptible to line voltage disturbances, reducing line harmonics propagation and improving overall power quality in systems where it is implemented.
6. Low voltage output: Standards for Safety Extra Low Voltage (SELV) output are met, making the PFM viable for applications where safety (direct as well as indirect contacts with human body) is a concern. Also, high-density bulk capacitance is widely available at this voltage level.
7. Isolated output: Insulation is guaranteed through magnetic coupling with no optical elements, thus improving the design reliability over time.
8. EMI and EMC compliance: The PFM module meets all the applicable international standards.

The PFM module merges state-of-the art technologies at various levels: topology, architecture, high-performance analog controls, supervisory digital controls and low-profile, surface-mount packaging. These technologies enable high density, optimized rectification power system designs across the universal AC input line.

VI Brick® AC-DC Front End Features and Benefits

The PFM® powers the VI Brick Isolated AC Front End with Power Factor Correction and integrated rectification, filtering and transient protection in a low profile (9,55mm) package. Output power of 330 W is available with up to 100°C baseplate temperature, with full-load efficiency exceeding 90% on 100–120 V_{RMS} AC mains and 92% on 220–230 V_{RMS} AC lines. DC output safe operating area is invariant with respect to input voltage within the range 85–264 V_{RMS}.

Despite the filtering and transient suppression components, the module achieves a remarkable density of 121 W/in³ (7.4 W/cm³) and provides 48 V output with 3 k_{VAC}, 4.2 k_{VDC} isolation on the input. The overall efficiency and thermally enhanced packaging minimize heat sink requirements. The AC Front End module is a state-of-the-art converter solution that can be implemented in any system with minimal electrical and mechanical design effort.

Energy storage is conveniently located on the secondary side and is not subject to line voltage surges or disturbances. Accordingly, high density 63 V rated hold-up capacitors can be implemented with good reliability.

Conclusion

Vicor's AC Front End module, powered by the PFM module, enables high-efficiency and high-density power factor corrected rectification, consistently across universal input voltage range. Total harmonic distortion exceeds EN61000-3-2 requirements, while high switching frequency and resonant transitions simplify external filtering and compliance to EMI standards. State-of-the-art supervisory digital controls also reduce propagation of AC line harmonics, improving overall power quality at system and facility level. The low profile, PCB-mount VI Brick package also includes a high density conducted emissions line filter, which meets EN55022 class B Standard, with a few external components, and line surge protections, which meet EN61000-4-5 Standard.

Figure 1.

Classic PFC rectifier control,
multiplier based

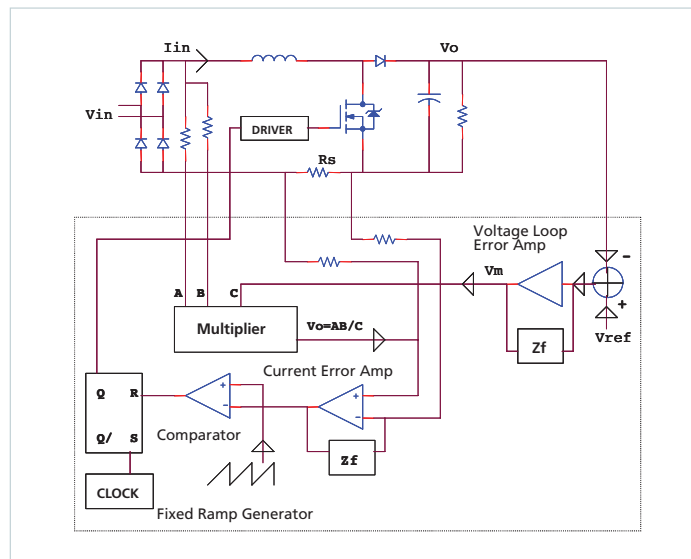

Figure 2.
One-Cycle Control (resettable
integrator) PFC rectifier control

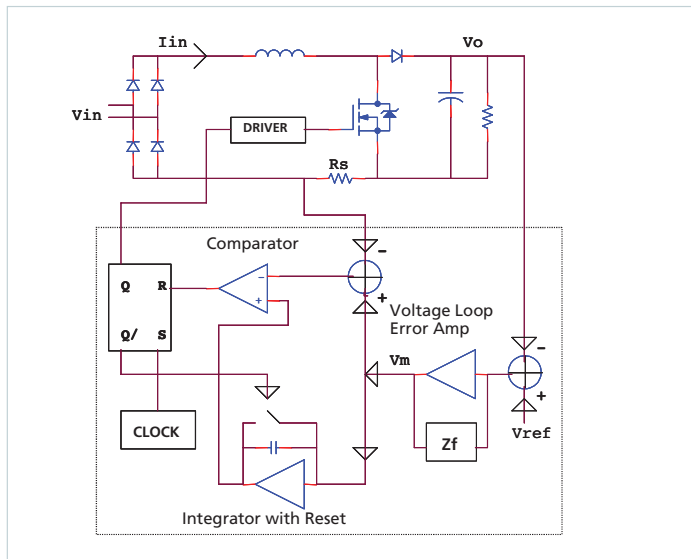

Figure 3.
Double Clamp, Zero-Voltage
Switching converter
schematic diagram

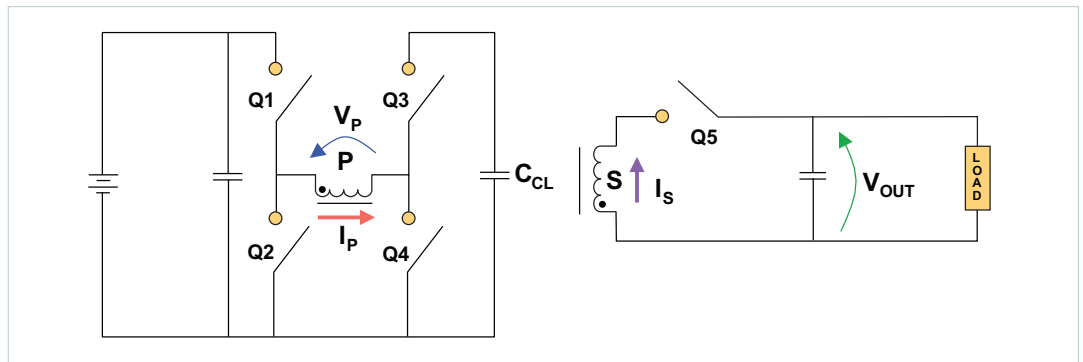

Figure 4.
Double Clamp, Zero-Voltage
Switching converter
topological waveforms

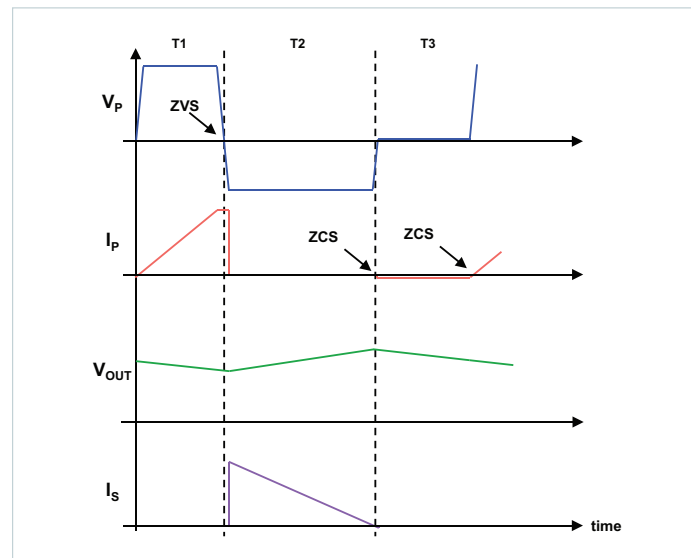

Figure 5.
Adaptive Cell™ dynamic
architecture schematic diagram

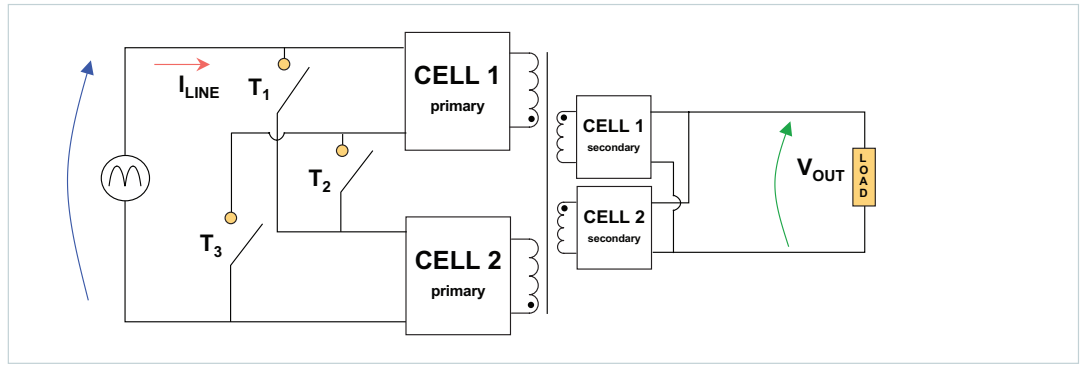
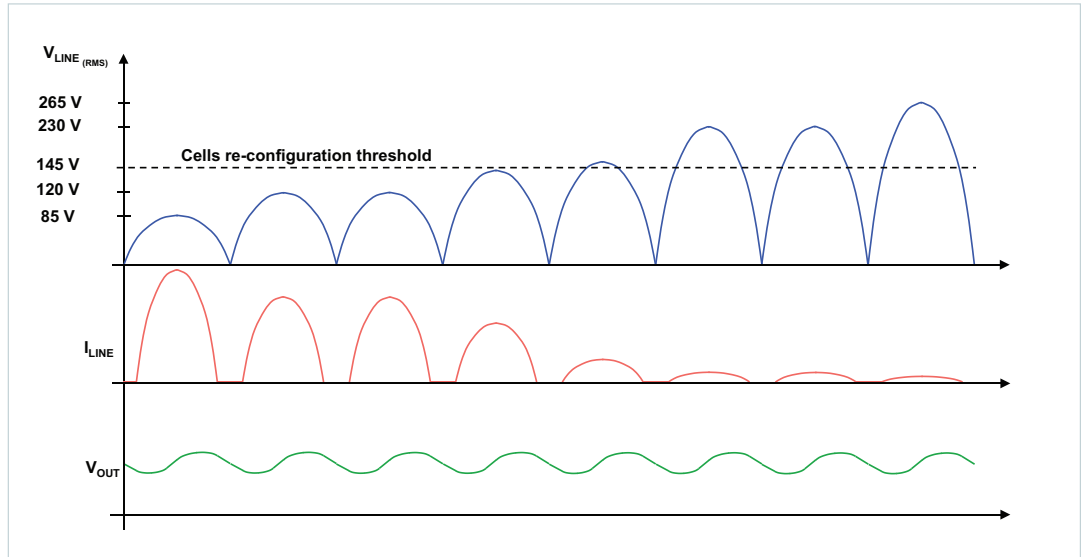

Figure 6.
PFM module topological
waveforms



The Power Behind Performance